

# A mathematical programming approach to railway network asset management

C. Fecarotti & J. Andrews

*Resilience Engineering Research Group, Department of Civil Engineering  
The University of Nottingham, Nottingham, United Kingdom*

**ABSTRACT:** A main challenge in railway asset management is selecting the maintenance strategies to apply to each asset on the network in order to effectively manage the railway infrastructure given that some performance and safety targets have to be met under budget constraints. Due to economic, functional and operational dependencies between different assets and different sections of the network, optimal solutions at network level not always include the best strategies available for each asset group.

This paper presents a modelling approach to support decisions on how to effectively maintain a railway infrastructure system. For each railway asset, asset state models combining degradation and maintenance are used to assess the impact of any maintenance strategy on the future asset performance. The asset state models inform a network-level optimisation model aimed at selecting the best combination of maintenance strategies to manage each section of a given railway network in order to minimise the impact of the assets conditions on service, given budget constraints and performance targets. The optimisation problem is formulated as an integer-programming model. By varying the model parameters, scenario analysis can be performed so that the infrastructure manager is provided with a range of solutions for different combination of budget available and performance targets.

## 1 INTRODUCTION

The railway system is the result of the interaction of a number of different systems and infrastructure with the ultimate aim of transporting people and goods safely and on time. It consists of a diverse portfolio of assets, each bounds to deliver a specific function but all together contributing to ultimately provide a reliable and safe service. Each railway asset is subject to degradation and failure processes, and maintenance is performed in order to control the state of the assets and ensure that each asset's function is performed to the required standard. Maintenance policies are developed as a combination of periodic inspection, routine and emergency maintenance, enhancement and renewal activities, and these are specific to each railway asset. As maintenance resources and budget are limited, decisions have to be made on how to optimally allocate the available resources among all the asset on the network. Infrastructure asset management is the process of allocating maintenance resources among the assets comprising the system with the aim of minimising the whole-life costs while maximising the system performance. Optimal asset management involves decision making and selection of the best intervention strategy for each asset along the network in order to ensure that the required level of service

reliability and safety risk is achieved within budget. Determining the best set of strategies for a given network does not simply consist in choosing the strategy which is optimal for each asset. When a network perspective is adopted dependencies among different assets and different sections of the network arise, due for example to resource availability. This implies that intervention strategies that are optimal when an asset is considered individually, might not be optimal when decisions are made at a network level.

### 1.1 *Modelling approaches to infrastructure asset management optimisation*

Optimisation models have been presented in the literature to support infrastructure asset management from different perspectives and to address different aspects of the problem. Two main approaches to the optimisation of infrastructure asset management can be identified: asset-level and system-level optimisation. Asset-level optimisation aims at determining optimal maintenance policies for an individual asset, while system-level optimisation seeks the optimal combination of maintenance policies for all the assets comprising the system. The focus of this paper is on system-level optimisation; in the following, the modelling approaches developed in the literature to determine the optimal

set of maintenance policies for infrastructure systems composed of multiple assets are briefly discussed .

The authors in (Yeo, Yoon, & Madanat 2012) address the problem of planning maintenance for a system of heterogeneous facilities undergoing stochastic deterioration over a finite time horizon. They develop a two-stage bottom-up approach according to which optimal maintenance policies are first determined for each facility. The deterioration of each facility is modelled as a Markov process. The state of the facilities is known at the beginning of every year when inspection is performed and maintenance activities are selected year by year. The authors apply a dynamic programming approach to find the optimal activity as well as the alternative near optimal activities and associated costs for each facility. Then, a system-level optimisation is developed to obtain the combination of activities, one for each facility, that minimise the system expected cost-to-go while the agency cost (cost of the maintenance activities) is kept within a given budget. All facilities in the system are considered to be independent and the system-level optimisation problem is formulated as a constrained combinatorial problem.

A similar approach has been used in (Furuya & Madanat 2013) with application to a hypothetical railway system, where facility-level and system-level optimisation are combined to obtain the best combination of activities for all facilities in a given network. The authors demonstrate their approach on a hypothetical dual redundant railway network. A number of facilities are associated to each link in the network, and a set of available maintenance activities is considered for each facility. As in (Yeo, Yoon, & Madanat 2012), the degradation and maintenance of the railway assets is modelled as a Markov process, and the facility-level optimisation problem is formulated as a Markov decision process solved through dynamic programming. In the system-level optimisation problem, the budget constraint includes the cost reduction that can be achieved when adjacent facilities are maintained simultaneously. Constraints are also formulated on the minimum capacity to be guaranteed between an origin and a destination node and for each individual route. This enables to consider the loss of throughput due to maintaining adjacent facilities simultaneously. A numerical example is solved, which demonstrates how including both economic (opportunistic maintenance) and functional (capacity loss) dependencies arising between the assets when performing maintenance, has an impact on the optimal decision and associated lifecycle cost.

In (Robelin & Madanat 2008) the authors address the optimisation of maintenance policies for a system of bridge decks with the objective of determining the optimal set of policies based on the current system conditions as well as the prediction of future conditions. The deterioration model of an individual deck is Markovian, where each state is defined in terms of the current condition of the deck, the last maintenance

action performed and the time since the last intervention. The condition of a deck is given by its instantaneous probability of failure. A two-steps approach is suggested. First, a facility-level optimisation is solved to obtain the optimal cost of maintenance and replacement for each facility. The facility-level optimisation problem is solved for a discrete range of failure probabilities. Then, at system level, the cost of the system given by the combination of the cost for each facility, is minimised subject to budget constraint, and the optimal threshold of failure probability is obtained. This threshold is used backward within the facility-level optimisation to obtain the set of policies for each deck which are optimal at system level. Some of the assumptions the optimisation model in (Robelin & Madanat 2008) is based on are too restrictive to be applied to the railway system. Many of the railway assets exhibit multiple failure modes, each with different probabilities and frequencies of occurrence. Different failure modes usually have different effects on system performance and must be therefore considered individually. Decisions on maintenance policies must account for the different failure modes so that different effects on service performance can be distinguished, and both safety and performance requirements can be addressed in a cost effective manner. Another simplifying assumption made in this paper is that at system level, the optimal threshold of probability of failure is the same for all the facilities. While this makes the optimisation problem easier to solve, it also produces a less realistic model. In real systems the location of the assets on the network may play an important role within the decision making process. The railway network includes lines and routes with different criticalities corresponding to different safety and service performance targets. It is often the case that in the trade-off between cost and performance, more expensive policies are likely to be implemented on assets located on lines with higher criticality, while lower performance is accepted on lower criticality lines.

The author in (Durango-Cohen 2007) presents a method to simultaneously address the conditions and costs forecasting problem and the optimisation of maintenance action for transportation infrastructure facilities. Facilities deterioration is represented as an autoregressive moving average with exogenous input model (ARMAX). Decision variables can be investment levels or maintenance rates and the optimisation problem is formulated as a dynamic program seeking the minimum expected discounted cost over the planning horizon. Decisions are made based on the information available at the beginning of the planning period. The use of the ARMAX model is based on the assumption that the effects of maintenance actions are linear and additive. This assumption however is too restrictive for many railway assets (e.g. track) as it completely disregards the complexity of the combined effects of different interventions on the future

asset state and the consequent impact on costs.

The approach presented in the aforementioned papers is aimed at selecting the maintenance policies to be adopted year by year over a given time horizon. Inspection is not considered as part of the policies as it is assumed to be carried out at the beginning of every year. However, the frequency of inspection is an important aspect of every maintenance policy as it allows to reveal the conditions of an asset before failures occur or unacceptable degraded states are reached. Indeed it is the optimal combination of inspection frequency, threshold values for assets conditions triggering interventions and the time required to perform maintenance that make an effective maintenance strategy. Furthermore, most of the contributions use a Markov approach to model the degradation and maintenance processes of the assets. However, the Markov approach has a few limitations that prevent it from being an effective modelling tool for many of the railway assets. A significant limitation is the requirement of Markov models to restrict transitions between states on the model (generally representing degradation or repair) to occur at a constant rate. This means that the state residence times are exponentially distributed. The memoryless property of the Markov approach restricts the ability of the model to consider the maintenance history which is important in some of the railway asset components such as the track ballast. Furthermore, the size of a Markov model can experience a state-space explosion with the number of components considered, thus making difficult to model assets with many different components or formed linking several sections of track. One final significant limitation is its inability to represent a route or network perspective. If Markov models exist for two assets and it is required to account for their dependencies in constructing a route model, this can only be accomplished by the generation of a completely new model.

An alternative modelling technique that overcomes some of the limitations of the Markov approach in modelling railway asset degradation and maintenance is the Petri Net (PN) method. PNs are a formalism for modelling complex, dynamic systems characterised by concurrency and dependencies, synchronisation and resource sharing. PNs provide a valuable mathematical and graphical description of the system behaviour. PNs is a stochastic technique which allows far greater detail in comparison to the alternatives when modelling assets degradation and complex management strategies, whilst maintaining a manageable model size. PNs account for any distribution of degradation and failure times; thus increasing failure rate typical of components subject to wear-out can be considered. PNs also enable the modelling of complex maintenance processes including condition and risk based inspection and maintenance, replacement prior to failure based on either age, condition or use, reactive repair, refurbishment and renewal and all the rules

for the implementation of such activities. The resulting PN models are usually smaller in size than the alternative Markov representation. An additional and very desirable feature of PN models is their modularity. Models of assets consisting of many interacting components can be built up in parts giving the model a modular structure which is easier to analyse. Monte Carlo simulation is the most common solution technique for PN models and produces distributions for the output variables of interest. The PN approach is suggested in this paper as a valid modelling technique to produce models that combine the degradation and maintenance processes involving the railway assets. Such models can be used as a tool to investigate the effectiveness of a variety of maintenance strategies for each railway asset, covering a range of performance and costs, so to provide the decision maker with a set of potential strategies among which the ones which are best from a system perspective can be selected.

## 2 THE METHODOLOGY

This paper presents a modelling approach to support decisions on how to effectively maintain a railway infrastructure system. First, for each railway asset, a modelling tool is required to assess the asset response to the implementation of a range of feasible maintenance strategies. Such modelling tools, called *asset state models* combine the degradation/failure processes affecting the asset with the intervention activities that can be performed in order to predict the future asset state. The asset state models developed for each asset inform a network-level optimisation model aimed at selecting the best combination of maintenance strategies to manage all the assets on a railway network under budget and performance constraints. The network-level optimisation model is formulated as an integer program with multiple constraints (Hillier & Lieberman 2009). The model is bounded to select one option for each individual asset located in the considered railway network. Constraints are formulated on the overall available budget and on the availability required of each railway line. Different lines in the network may have a different criticality depending on the effect that failures have on service. This is strictly linked to the frequency of the service running on each line. Different lines criticality are accounted for by imposing different thresholds to the availability of each line. This modelling approach has the advantage to enable the evaluation of a variety of different scenarios by changing the model parameters such as the available budget or the threshold levels set for the lines availability.

### 2.1 *Network segmentation for strategic planning purposes*

The UK railway network is segmented for policy decisions. The whole network is divided into 19 Strate-

gic Routes, each divided into a number of Strategic Route Sections (SRSs). An SRS is a section of the railway network characterised by broadly homogeneous infrastructure type and traffic levels. Therefore strategy decisions are taken at SRS level. It is assumed that the same maintenance strategy will be applied within the same SRS. Asset state models are developed for each asset type existing on each SRS and are used to assess the impact of a range of maintenance strategies on the assets' performance.

## 2.2 Asset state models

The PN method is adopted as the modelling approach to develop the asset state models. PNs are a formalism for modelling complex distributed systems characterised by concurrency and dependency, synchronization and resource sharing. Petri nets provide a valuable mathematical and graphical description of the system behaviour. A PN is a directed, weighted bi-partite graph where nodes are places and transitions connected by arcs (Murata 1989). A PN can be formally defined as follows.

**Definition 1.** A PN is a 5-tuple  $PN = (P, T, A, W, M_0)$  where:  $P = \{p_1, p_2, \dots, p_m\}$  is the non-empty set of places,  $T = \{t_1, t_2, \dots, t_n\}$  is the non-empty set of transitions,  $P \cap T = \emptyset$ ,  $A \subseteq (P \times T) \cup (T \times P)$  is the set of arcs,  $W : A \rightarrow \{1, 2, \dots\}$  is the multiplicity function,  $M_0 : P \rightarrow \{0, 1, 2, \dots\}$  is the initial marking.

Places may represent physical resources, conditions or the state of a component. Tokens are held in places and the number of tokens in each place defines the marking of the Petri net which represents the state of the system at a given time. The flow of tokens through the network is determined by transitions and represents the evolution of the system state over time. Transitions represent events that make the status of the system change. Arcs only connect places with transitions (input arcs) and vice versa (output arcs). Inhibitor arcs are defined as well, which can be used to stop the firing of a transition under certain circumstances. Arcs are characterised by a multiplicity. The marking and the multiplicity of the arcs determine the enabling conditions for each transition. Transitions can be deterministic or stochastic. The former have an associated constant firing time, while the latter sample their firing time from stochastic distributions. Firing of transitions is ruled as follow:

- If the number of tokens contained in the input places is at least equal to the multiplicity of the associated input arcs, and the number of tokens in the places connected by inhibitor arcs is lower than the arcs multiplicity, then the transition is enabled.
- Once the transition is enabled, it will fire after a time interval which is fixed for deterministic

transitions. For stochastic transitions the firing time is sampled from a probabilistic distribution.

- When the firing time is reached and the transition fires, a number of tokens is removed from the input places and added to the output places according to the arcs multiplicity.

For the purpose of maintenance, a number of discrete states are usually considered, corresponding to levels of degradation that trigger maintenance interventions with different levels of urgency. The degradation process can therefore be represented as a chain of places and transitions as shown in Figure 1. Places

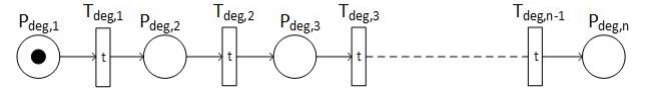

Figure 1: Degradation

$P_{deg,i}$  indicate different states which are relevant from a maintenance perspective, namely each state (except for the new state  $P_{new}$ ) triggers maintenance with different level of urgency depending on the level of degradation. Transitions  $T_{deg,i}$  represent the degradation from one state to the next (worse). These are stochastic transitions whose firing time is sampled from a stochastic distribution representing the distribution of times to degrade between two consecutive states. Asset conditions requiring a speed restriction or a line closure can be included as well, these being usually the last two levels of degradation. Inspection is performed periodically to reveal the current asset condition so that degraded states can be discovered and maintenance planned accordingly. In Figure 2) transitions  $T_{rev,i}$  are timed deterministic and fire at a fixed frequency. Once a degraded condition is

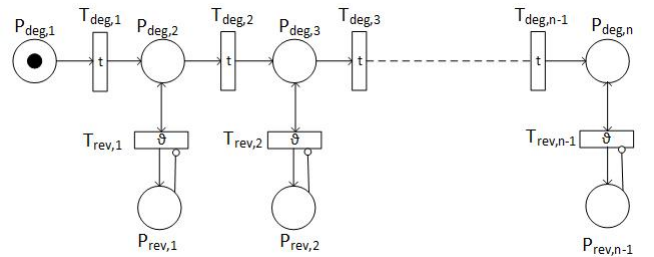

Figure 2: Degradation and inspection

revealed, maintenance is planned depending on the level of urgency. Maintenance interventions are represented by transitions  $T_{rep,i}$  (Figure 3). After maintenance, the asset is usually restored to a good condition ( $P_{good}$ ) rather than to new, unless a renewal is carried out. If necessary, it is possible to account for the effectiveness of maintenance by adopting a probabilistic routing policy for transitions  $T_{rep,i}$  so that the state after maintenance can be any of the degraded state with

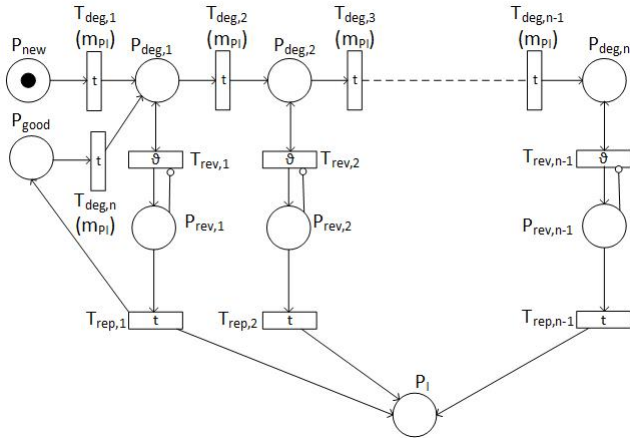

Figure 3: Degradation, inspection and repair

a given probability. It is also possible to keep track of the number of maintenance interventions performed. This is achieved by monitoring the marking of place  $PI$  which is marked every time an intervention is performed (and therefore any of transitions  $T_{rep,i}$  fires). For some assets, the degradation might depend on the past maintenance history; an example is the ballast for which the rate of degradation increases with the number of tamping interventions performed. This can be accounted for if transitions  $T_{deg,i}$  update their distributions of times to degrade according to number of interventions performed on the asset. This modelling approach enables the evaluation of a wide range of maintenance strategies, for each of which it is possible to specify the inspection frequency, the thresholds on the asset conditions that trigger maintenance, the mean time to schedule and perform any maintenance activity. Furthermore, by keeping track of the marking during the simulation, it is possible to evaluate the probability of being in any of the considered states as well as the number of interventions performed. The probability of having a speed restriction and a line closure is of particular interest to evaluate the impact of a given strategy on service and safety risk.

This modelling structure can be used as a *modelling template* to describe a variety of railway asset exhibiting degradation during their lifetime. The number and features of places and transitions representing the degradation processes and the maintenance activities can be easily fitted to characteristics of the specific asset to be modelled. Example of degradation and maintenance models adopting a similar structure have been proposed in the literature for a number of railway assets such as track (Andrews 2012, Prescott & Andrews 2013, Andrews, Prescott, & De Rozières 2014) and bridges (Le & Andrews 2016, Le, Andrews, & Fecarotti 2017).

### 2.3 Network-level strategies optimisation

The analysis conducted by means of the asset state models results in a set of potential asset management strategies covering a range of performance levels for

each asset group. Given a set of potential strategies for each asset group, the infrastructure manager is faced with the task of selecting one strategy for each asset on the network given that a limited budget is available. Performance and safety targets are usually set for each route and line along the network, and these targets can be different depending on the route criticality. Decisions are therefore bounded by the available budget and are made with the aim of minimising the disruption caused to the railway service, while a certain level of availability is ensured for each line depending on the line criticality. Whatever asset fails, the impact on trains service is due to either a speed restriction, leading to delays, or a section closure leading to journeys cancellation. The extent of the disruption depends on both the duration of such control actions and the location of the section(s) involved. If a speed restriction or a section closure is imposed on a section belonging to a high frequency line, or to more than one line, then the number of journey affected by the disruption will be high. With regard to the impact of failures on service, for each section in the network is therefore fair to define two failure modes, each with a different effect on service: (i) section subject to speed restriction, and (ii) section subject to closure.

Let us define a Strategic Route as a set of SRSs  $R = \{R_1, R_2, \dots, R_i, \dots, R_{n_R}\}$ . Railway services run along a set of railway lines  $L = \{L_1, L_2, \dots, L_l, \dots, L_{n_L}\}$ , each railway line consists of one or more SRSs. Therefore each railway line can be represented as a subset of set  $R$ ,  $L_l \subseteq R, \forall l = 1, \dots, n_L$ . A railway line  $L_l$  will be unavailable if any of its SRS is unavailable. If  $a$  is the number of asset groups considered and  $b$  is the number of strategies available for each asset group, then the set of maintenance strategies for each SRS is given by all the possible combinations of the individual asset groups' strategies  $n_S = a \times b$ . The set  $S = \{S_1, S_2, \dots, S_j, \dots, S_{n_S}\}$  is defined, containing  $n_S$  potential strategies available for each SRS, each corresponding to a given combination of the individual asset strategies. From now on the term strategy will be used to indicate a strategy for the individual SRS, among the available ones in set  $S$ . The index  $j = 1, 2, \dots, n_S$  will be used to refer to a generic strategy within set  $S$  while the index  $i = 1, 2, \dots, n_R$  will be used to refer to a generic SRS within set  $R$ . The vector of decisional variables  $X$  has components  $x_{ij}$  such that  $x_{ij} = 1$  if strategy  $j$  is applied to SRS  $i$ , 0 otherwise. The infrastructure manager is bounded to choose only one strategy per SRS. Following the implementation of a given strategy, each SRS will be subjected to a given probability, average number and duration of imposed speed restrictions and section closure during the considered planning period. Section closure contributes to define the availability of the SRS. In fact a section closure means that the section is not available for use and therefore all the journeys that use that section are cancelled or rerouted if possible. If a speed restriction is imposed, trains



can still run but at a reduced speed; this implies delays and sometimes journey cancellations. Therefore we assume that the number and duration of imposed speed restrictions implicitly provide an indication of the impact on service delay. Similarly, we assume that the number and duration of imposed section closure implicitly provide indication of the deleted services due to section unavailability. The problem is formulated as follows:

$$\min Z(X) = \sum_{i=1}^{n_R} \sum_{j=1}^{n_S} n_{ij}^{(SR)} \cdot d_{ij}^{(SR)} \cdot f_i \cdot x_{ij} \quad s.t \quad (1)$$

$$\sum_{j=1}^{n_S} x_{ij} = 1 \quad \forall i = 1, 2, \dots, n_R, \quad (2)$$

$$\sum_{i=1}^{n_R} \sum_{j=1}^{n_S} c_{ij} x_{ij} \leq B, \quad (3)$$

$$Q_{L_l}(x_{ij}) \leq Q_{L_l}^* \quad \forall L_l \in L, \quad (4)$$

$$x_{ij} \in \{0, 1\} \quad \forall i = 1, 2, \dots, n_R; \quad j = 1, 2, \dots, n_S. \quad (5)$$

where the model parameters are:

- $n_{ij}^{(LC)}$  the average number of closures in SRS  $i$  following implementation of strategy  $j$ ,
- $d_{ij}^{(LC)}$  the average duration of closures in SRS  $i$  following implementation of strategy  $j$ ,
- $n_{ij}^{(SR)}$  the average number of speed restriction imposed on SRS  $i$  following implementation of strategy  $j$ ,
- $d_{ij}^{(SR)}$  the average duration of speed restriction imposed on SRS  $i$  following implementation of strategy  $j$ ,
- $q_{ij}^{(LC)}$  the probability of a closure in SRS  $i$  following implementation of strategy  $j$ ,
- $Q_{L_l}^*$  the threshold on the unavailability of line  $L_l$ ,
- $c_{ij}$  the cost of strategy  $j$  implemented on SRS  $i$ ,
- $f_i$  the frequency of trains travelling on SRS  $i$ ,
- $B$  the available budget.

The objective function  $Z(X)$  is representative of the impact that the selected combination of strategies has on service delay, which allows to compare different solutions. It represent the expected number of trains affected by a service disruption during the considered time horizon. Each term  $n_{ij}^{(SR)} \cdot d_{ij}^{(SR)} \cdot f_i \cdot x_{ij}$  gives an indication of the contribution of each SRS to the overall service disruption. This contribution

is proportional to the average number of speed restrictions imposed on the SRS and its average duration, and on the frequency of trains travelling through the SRS. The train frequency is used to weight each SRS proportionally to the normalised amount of flow travelling on the SRS. The frequency also implicitly weight each SRS based on the its centrality, namely its role in serving more than one line. The set of constraints 2 indicates that only one strategy can be selected for each link. Constraint 3 adds a bound on the overall costs according to the available budget. The set of constraints 4 put a threshold on the minimum value of unavailability of each line. A line is unavailable if any of its SRSs is closed. Therefore, the probability of line  $L_l$  being closed  $Q_{L_l}(x_{ij})$  can be written as

$$Q_{L_l}(X) = 1 - \prod_{\forall i | R_i \in L_l} (1 - \sum_{\forall j | S_j \in S} q_{ij}^{(LC)} \cdot x_{ij}) \quad (6)$$

The optimal solution  $X^*$  is given by the feasible combination of strategies that will provide the minimum impact on service as represented by the objective function  $Z^*(X)$ . The objective function in 1  $Z(X)$  is linear in  $X$ , as constraints (1) and (2), while constraints (3) are non-linear. Problem 1 is therefore a non-linear integer optimisation problem.

### 2.3.1 Solution method

There are no general-purpose solution methods yielding the global optimum for non-linear (non-convex) constrained optimisation problems and approximate solution algorithms are usually used. However, it possible to solve a linear approximation of the original problem if the non-linear functions (objective function and/or constraints) can be converted to an acceptable linear form.

Problem 1 is transformed into a linear integer programming model by replacing the left hand side of constraint 4 with its *rare event approximation* (Andrews & Moss 2002) as follows:

$$\begin{aligned} Q_{L_l}(X) &= 1 - \prod_{\forall i | R_i \in L_l} (1 - \sum_{\forall j | S_j \in S} q_{ij}^{(LC)} \cdot x_{ij}) \\ &\leq \sum_{\forall i | R_i \in L_l} \sum_{\forall j | S_j \in S} q_{ij}^{(LC)} \cdot x_{ij}. \end{aligned} \quad (7)$$

The rare event approximation is an upper bound to the top event exact probability and can be used when the probability of the basic events is low. This an acceptable approximation for the problem at hand as the probability of a link closure is usually small.

Integer programming is NP-hard, namely it can be solved in non-polynomial time. Therefore, depending on the problem size it can be difficult to solve in reasonable computational time. In such circumstances,

Table 1: SRSs and trains frequency.

SRS	Train per hour
01 London St. Pancras-Bedford	20
02 Bedford-Nottingham	8
03 Wichnor Jn/Long Eaton-Chesterfield	8
04 Chesterfield-Nottingham	4
05 Nottingham-Newark Castle	1
06 Matlock-Ambergate	1
07 Netherfield-Grantham	2

the associated relaxed problem obtained through Continuous relaxation can be studied. The relaxed problem is a linear continuous programming model which can be solved by means of the simplex method. The optimal solution of the relaxed problem is a lower bound of the global optimum of the original problem.

### 3 NUMERICAL EXAMPLE

The optimisation approach presented in this paper has been applied to select the best combination of maintenance strategies for a set of SRSs comprising one of the UK Strategic Routes, the East Midlands (EM) Route. Details of the EM route and its SRSs can be found in (NetworkRail 2015). A schematic representation of part of the EM route showing seven of its eleven SRSs is given in Figure 4. The set of SRSs

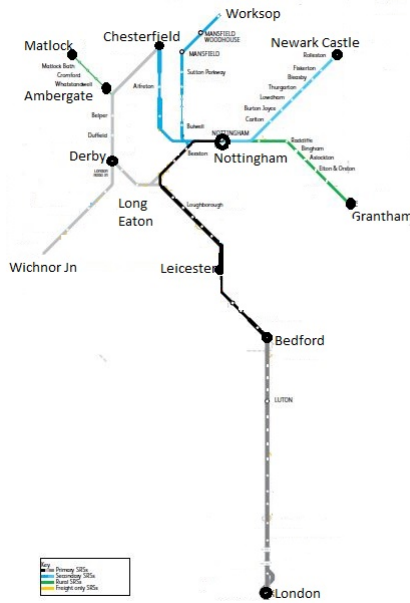

Figure 4: Map of part of the EM Route, including SRSs 11.01 to 11.07

considered in this example are listed in Table 1 along with the train frequency.

Railway services running along the EM Route which have been considered here are listed in Table 2 along with the service type (Long distance high speed -LDHS, interurban and local), while Table 3 lists the SRSs included within each service.

For each railway service, different availability requirements are considered depending on the type of service. Three potential maintenance strategies are

Table 2: Railway services.

Service name	Service type
London St.Pancras to Nottingham	LDHS
London St.Pancras to Sheffield(via Derby)	LDHS
Norwich to Liverpool	Interurban
Nottingham to Leeds	Interurban
Newark Castle-Nottingham-Derby-Matlock	local

Table 3: SRSs included within each railway service.

Service name	SRSs
London St.Pancras to Nottingham	{01, 02}
London St.Pancras to Sheffield(via Derby)	{01, 02, 03}
Norwich to Liverpool	{02, 04, 07}
Nottingham to Leeds	{02, 04}
Newark Castle-Nottingham-Derby-Matlock	{02, 03, 05, 06}

considered,  $S = \{S_1, S_2, S_3\}$ . The evaluation of the maintenance strategies through the PN asset models yields the input parameters to the optimisation model. The values of the model parameters used to run this numerical example are detailed in Table 4 where  $c_i$ ,  $q_i$  and  $n_i^{SR}$  indicate the cost, unavailability and number of speed restriction due to the implementation of the available strategies.

Table 4: Model parameters.

SRS	$c_1$	$c_2$	$c_3$	$q_1$	$q_2$	$q_3$	$n_1^{SR}$	$n_2^{SR}$	$n_3^{SR}$
01	50	70	85	0.9	0.95	0.99	4.7	3.8	2.5
02	50	70	85	0.9	0.95	0.99	4.7	3.8	2.5
03	60	80	95	0.9	0.95	0.99	4.7	3.8	2.5
04	60	80	95	0.9	0.95	0.99	4.7	3.8	2.5
05	60	80	95	0.9	0.95	0.99	4.7	3.8	2.5
06	50	70	85	0.9	0.95	0.99	4.7	3.8	2.5
07	60	80	95	0.9	0.95	0.99	4.7	3.8	2.5

The optimisation model has been solved for eight different values of the available budget  $B_1 = 350$ ,  $B_2 = 400$ ,  $B_3 = 450$ ,  $B_4 = 500$ ,  $B_5 = 550$ ,  $B_6 = 600$ ,  $B_7 = 650$ ,  $B_8 = 700$ , while the thresholds on the unavailability of each railway service remain unchanged and equal to  $Q_{L_1}^* = 0.98$ ,  $Q_{L_2}^* = 0.98$ ,  $Q_{L_3}^* = 0.98$ ,  $Q_{L_4}^* = 0.95$ ,  $Q_{L_5}^* = 0.9$ . The results of the scenario analysis are summarised in Table 5 and Figure 5. Table 5 details the optimal maintenance strategies for each SRS, while Figure 5 shows the corresponding value of the objective function which is indicative of the expected number of trains affected by a speed restriction.

Table 5: Maintenance strategies selected.

Scenario	SRS						
	01	02	03	04	05	06	07
1	-	-	-	-	-	-	-
2	-	-	-	-	-	-	-
3	-	-	-	-	-	-	-
4	-	-	-	-	-	-	-
5	$S_3$	$S_3$	$S_3$	$S_3$	$S_1$	$S_1$	$S_2$
6	$S_3$	$S_3$	$S_3$	$S_3$	$S_1$	$S_3$	$S_3$
7	$S_3$	$S_3$	$S_3$	$S_3$	$S_3$	$S_3$	$S_3$
8	$S_3$	$S_3$	$S_3$	$S_3$	$S_3$	$S_3$	$S_3$

Results show that no feasible solution can be found for budgets  $B_1$  to  $B_4$  as the strategies that would be achievable within the available budget do not ensure

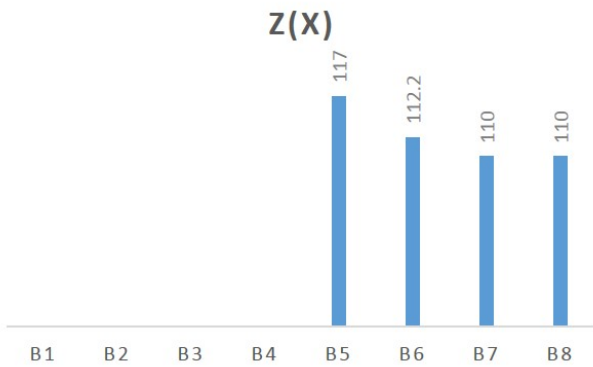

Figure 5: Expected number of disrupted trains for different available budgets.

the required level of availability for each railway service. If the budget is increased solutions can be found. Budget  $B_5$  is enough to find a feasible solution but does not allow the selection of the best strategy available for each SRSs. The algorithm selects less expensive strategies for SRSs 05, 06 and 07 as they belong to those railway services for which a less restrictive value of availability is required. Furthermore, the train frequency on those sections is lower than in the others. By further increasing the available budget, better strategies can be chosen and the impact on service decreases.

#### 4 CONCLUSIONS

This paper presents a modelling approach to support decisions on how to effectively maintain a railway infrastructure system. First, for each railway asset, a modelling tool is required to assess the asset response to the implementation of a range of feasible maintenance strategies. Such modelling tools, called *asset state models* combine the degradation/failure processes affecting the asset with the intervention activities that can be performed in order to predict the future asset state. The modelling approach suggested to develop the asset state models is the PN method. A modelling template based on the PN method have been presented, which can be specified to represent a variety of railway assets undergoing degradation and ageing. The asset state models developed for each asset inform a network-level optimisation model aimed at selecting the best combination of maintenance strategies to manage all the assets on a railway network under budget and performance constraints. The network-level optimisation model is formulated as an integer program with multiple constraints. A numerical example has been presented to show the capabilities of the optimisation model. An advantage of mathematical programming formulation is that the model is not a black box. Furthermore, when the problem size is such that global solutions cannot be found in reasonable computational time, the mathematical programming formulation allows the use of tools to

estimate the goodness of approximate solutions. By varying the model parameters, scenario analysis can be performed so that the infrastructure manager is provided with a range of solutions for different combination of budget available and performance targets.

#### ACKNOWLEDGMENTS

John Andrews is the Royal Academy of Engineering and Network Rail Professor of Infrastructure Asset Management. He is also Director of The Lloyds Register Foundation Resilience Engineering Research Group at the University of Nottingham. Claudia Fecarotti is a Research Associate supported by Network Rail. They both gratefully acknowledge the support of these organisations.

#### REFERENCES

- Andrews, J. (2012). A modelling approach to railway track asset management. *Proceedings of the Institution of Mechanical Engineers, Part F: Journal of Rail and Rapid Transit* 227(1), 56–73.
- Andrews, J., D. Prescott, & F. De Rozières (2014). A stochastic model for railway track asset management. *Reliability Engineering and System Safety* 130, 76–84.
- Andrews, J. D. & T. R. Moss (2002). *RELIABILITY and Risk Assessment*. Professional Engineering Publishing.
- Durango-Cohen, P. (2007). A time series analysis framework for transportation infrastructure management. *Transportation Research Part B* 41, 493–505.
- Furuya, A. & S. Madanat (2013). Accounting for network for effects on railway asset management. *Journal of Transportation Engineering* 139, 92–100.
- Hillier, F. & J. Lieberman (2009). *Introduction to Operations Research*. McGraw-Hill Higher Education.
- Le, B. & J. Andrews (2016). Petri-net modelling of bridge asset management using maintenance-related conditions. *Structure and Infrastructure Engineering* 12(6), 730–751.
- Le, B., J. Andrews, & C. Fecarotti (2017). A petri net model for railway bridge maintenance. *Proceedings of the Institution of Mechanical Engineers, Part O: Journal of Risk and Reliability* 231(3), 306–323.
- Murata, T. (1989). Petri nets: properties, analysis and applications. *Proceedings of the IEEE* 77(4), 541–580.
- NetworkRail (2015). Route specifications: London north eastern and east midlands. Technical report.
- Prescott, D. & J. Andrews (2013). A track ballast maintenance and inspection model for a rail network. *Proceeding of the Institution of Mechanical Engineers, Part O: J Risk and Reliability* 227(3), 251–266.
- Robelin, C. A. & S. M. Madanat (2008). reliability-based system-level optimization of bridge maintenance and replacement decisions. *TRANSPORTATION SCIENCE*, 1–6.
- Yeo, H., Y. Yoon, & S. Madanat (2012). Algorithms for bottom up maintenance optimization for heterogeneous infrastructure systems. *Structure and Infrastructure Engineering* 1, 1–12.