

1 **Development of a composite substrate peel test to assess moisture**
2 **sensitivity of aggregate-bitumen bonds**

3
4 **Jizhe Zhang** (Corresponding author)

5 PhD Student

6 Nottingham Transportation Engineering Centre, Department of Civil Engineering
7 University of Nottingham, University Park, Nottingham NG7 2RD, United Kingdom
8 Tel: 01158468442; Email: evxjz3@nottingham.ac.uk

9
10 Gordon D. Airey

11 Professor

12 Nottingham Transportation Engineering Centre, Department of Civil Engineering
13 University of Nottingham, University Park, Nottingham NG7 2RD, United Kingdom

14
15 James Grenfell

16 Senior Technical Officer

17 Nottingham Transportation Engineering Centre, Department of Civil Engineering
18 University of Nottingham, University Park, Nottingham NG7 2RD, United Kingdom

19
20 Alex K. Apeagyei

21 Research Fellow

22 Nottingham Transportation Engineering Centre, Department of Civil Engineering
23 University of Nottingham, University Park, Nottingham NG7 2RD, United Kingdom

24
25 Martyn Barrett

26 Technical Officer

27 Nottingham Transportation Engineering Centre, Department of Civil Engineering
28 University of Nottingham, University Park, Nottingham NG7 2RD, United Kingdom

1 Abstract: Moisture damage in asphalt mixtures is a complicated mode of pavement distress
2 that results from the loss of interfacial adhesion between the aggregate and bitumen and/or
3 the loss of cohesion within the bitumen film. This paper presents the development of suitable
4 procedure to prepare peel test specimens using coarse aggregates and compare the results
5 with the established standard peel test. The newly developed composite substrate peel test
6 (CSPT) was found to be effective in characterising the moisture sensitivity of the aggregate-
7 bitumen bond and the results correlated well with the results from a standard peel test. The
8 results from the CSPT and the standard peel test showed that the fracture energy after
9 moisture damage was found to be aggregate type dependent. Based on the standard peel test
10 and CSPT, the moisture sensitivity of aggregate-bitumen bonds were evaluated by the
11 retained fracture energy. Limestone tends to have better resistance to moisture damage than
12 granite when moisture adsorptions are similar. Furthermore, in terms of similar aggregates,
13 lower moisture adsorption results in better moisture resistance. This phenomenon suggests
14 that in a susceptible asphalt mixture, the effect of aggregate may be more influential than the
15 effect of bitumen. Strong correlations were found between the standard peel test and the
16 CSPT in terms of moisture damage evaluation and suggest that the CSPT maybe a more
17 practical procedure to test the aggregate-bitumen bond for actual aggregates used in asphalt
18 mixtures.

19

20 **Keywords:** Peel test, bitumen, aggregate, moisture damage, CSPT

21

22 1. Introduction

23

24 The total road length in the UK is estimated to be approximately 250 thousand miles with
25 most of these roads being surfaced with asphalt mixtures [1]. Asphalt mixture is a composite

1 material consisting of aggregates (coarse and fine), bitumen and filler, mixed in a
2 predetermined ratio at high temperatures followed by compaction in order to produce a
3 flexible pavement [2]. When subjected to loading traffic, asphalt pavements deteriorate
4 gradually with the passage of time because of repeated traffic loading and environmental
5 attack [3]. In England and Wales, approximately 2.8 billion pounds are spent every year by
6 local authorities on road maintenance [4]. It is generally accepted that moisture damage is
7 one of the major causes of pavement deterioration.

8

9 Moisture damage in asphalt pavements can generally be classified as the gradual deterioration
10 of strength, stiffness and durability because of the presence of moisture in a liquid or vapour
11 state [5]. In addition, the presence of moisture can accelerate the distress of asphalt pavement
12 in several different modes, such as rutting, fatigue cracking, thermal cracking and the
13 formation of potholes [6, 7]. Recent research studies have also shown that moisture damage
14 maybe reversible under certain conditions [8]. In the field, the moisture damage normally
15 happens first at the interface of two pavement layers or at the bottom of pavement layers and
16 develops gradually upward. In addition, it has been observed that moisture damage is more
17 prone to occur in the wheel path in comparison with locations between the wheel paths or on
18 the shoulder [9].

19

20 There are several factors which may influence the development of moisture damage or
21 moisture sensitivity of an asphalt pavement, such as aggregate mineralogy, surface texture of
22 the aggregate, bitumen chemistry and the compatibility between aggregate and bitumen [10].
23 In addition, factors such as permeability of the asphalt mixtures, volumetric properties of the
24 asphalt mixture and the ambient conditions are all important when considering the
25 susceptibility of asphalt mixtures to moisture damage [11]. Based on previous research,

1 moisture damage is mainly characterised as the adhesive failure between aggregate and
2 bitumen or bitumen-filler (mastic) [12]. It has been suggested that the adhesion between
3 aggregate and bitumen in the dry condition and its degradation with the presence of water are
4 the two main attributes which determine the moisture sensitivity of pavements [13]. The
5 physico-chemical interactions between aggregates and bitumen in the presence of moisture
6 are believed to partially govern the moisture sensitivity of asphalt mixture, which can also
7 affect the serviceability, performance and durability of the asphalt pavement.

8

9 By evaluating the moisture damage of adhesion between aggregates and bitumen, efforts have
10 been made with numerous testing methods having been developed. Based on previous
11 research, standard tests on loose coated aggregates, such as the boiling water test and rolling
12 bottle test, are considered as direct methods to access moisture sensitivity by visual
13 inspection [14]. However, these tests rely on the basis of comparative evaluation so that the
14 results cannot be used to explain the actual mechanisms that contribute to moisture damage
15 and it is hard to correlate test data with field performance [15, 16]. So, it seems important to
16 develop testing techniques and procedures that can directly measure the strength of
17 aggregate-bitumen adhesive bond.

18

19 Over the past few years, several testing techniques used in other areas have been selected and
20 developed to measure the adhesion between aggregate and bitumen in the dry condition and
21 after moisture damage. The peel test is a method to measure the adhesive fracture energy of
22 the bonded interface of composited materials and has been successfully used to evaluate the
23 moisture sensitivity of different aggregate-bitumen combinations [17, 18]. This test is based
24 on the fracture mechanics approach to measure the adhesive fracture energy of aggregate-
25 bitumen joints tested in both the dry state and after being conditioned in moisture [19].

1

2 The peel test used for aggregate-bitumen adhesive testing requires the preparation of a large
3 flat aggregate surface with regular shape. In this case, only large stone boulders could be used
4 for the peel substrate preparation. This paper presents a newly designed procedure to prepare
5 a composite substrate using coarse aggregates as a practical alternative to the standard peel
6 test. The innovation of this procedure is the ability to combine several coarse aggregates
7 together and get a flat aggregate surface that can be easily used for the peel test rather than
8 use stone boulders. The paper evaluates the susceptibility of the aggregate-bitumen bonds to
9 moisture damage based on values obtained from the new CSPT as compared to the standard
10 peel test. The reliability of the newly developed composite substrate peel test (CSPT) was
11 evaluated using the standard peel test.

12

13 Four different types of aggregate (two limestones and two granites) and one type of bitumen
14 were selected for testing. The mechanical tests, consisting of the newly developed CSPT and
15 the standard peel test, were used for measuring retained fracture energy after moisture
16 conditioning. The moisture sensitivity of the aggregate-bitumen combinations were
17 characterised by analysing the results obtained from the mechanical tests. Finally, the
18 correlation between these two tests was analysed by comparing the moisture sensitivity
19 ranking of the two tests.

20

21 2. Materials

22

23 2.1 Bitumen

24

25 One 40/60 penetration grade bitumen was used in this study (bitumen B1). The properties of

1 the bitumen were measured using the softening point (BS EN 1427) and penetration (BS EN
2 1426) tests with softening point and penetration values of 51.2°C and 46 (0.1mm),
3 respectively.

4

5 2.2 Aggregates

6

7 Four types of aggregate (including boulders and coarse aggregates) from different quarries
8 were selected as substrates. They included two limestone ‘basic’ aggregates (L1 and L2) and
9 two granite ‘acidic’ aggregates (G1, G2). In this research, these four aggregates were used for
10 both the newly developed CSPT and standard peel test. The water absorption of these four
11 aggregates was evaluated according to the ASTM standard (ASTM C127-15) and the results
12 shown in Table 1. The results show that L1 has a far higher moisture absorption than L2 and
13 G2, which are very similar, while G1 has the lowest moisture absorption.

14

15 3. Experimental Programme

16

17 3.1 Mineral Liberation Analyser (MLA) test

18

19 The mineralogical compositions of aggregates have a significant influence on moisture
20 damage susceptibility of asphalt mixtures. The mineralogy of the different aggregates was
21 studied using a Mineral Liberation Analyser (MLA) in order to understand the effect of their
22 morphology on moisture damage resistance of aggregate-bitumen bonds. The experimental
23 procedures used for the mineralogical composition testing can be found in previous
24 publications [11, 20].

25

1 3.2 Peel test

2

3 The peel test (as described in ASTM D6862-11) is used to measure the fracture energy of
4 flexible laminates and is widely used in aerospace, automotive and electronics applications
5 [21, 22, 23]. This test is considered to be a reliable method to measure the peel strength
6 (fracture energy) if suitable corrections for plastic work can be performed [24].

7

8 3.2.1 Substrate preparation

9

10 For the peel testing, the specimen should be rectangular, with the rigid aggregate substrate
11 and the flexible peel arm adhered along most of the length. The rigid aggregate should be
12 thick enough to withstand the expected tensile force. The flexible peel arm should have good
13 adhesion with bitumen to avoid fracture at the interface. In this research, an aluminium alloy
14 with a thickness of 0.2 mm was selected as a flexible peel arm. According to previous
15 research [19], the aggregate substrates were produced from aggregate boulders with the
16 overall dimensions selected as 150 mm × 20 mm × 10 mm.

17

18 The stone boulders were first wet-sawn to get aggregate slabs with a thickness of 10 mm.
19 Then, the aggregate slabs were trimmed to a size of 150 mm long and 20 mm wide, as shown
20 in Figure 1a. In this case, only large stone boulders (>200 mm) could be used for the
21 substrate preparation. However, commonly used asphalt mixture aggregates are crushed
22 coarse aggregates (20 mm - 32 mm) which are significantly smaller than stone boulders.

23

24 This paper presents the development of a novel method to prepare a composite substrate
25 using crushed coarse aggregates (Figure 1b) as a more practical replacement for the aggregate

1 substrate prepared from boulders (Figure 1a). The innovation of this procedure is the ability
2 to combine several coarse aggregates together and get a flat surface that can be used for the
3 peel test.

4

5 In order to combine the coarse aggregates together, a mould made up from five aluminium
6 plates was designed and shown in the schematic diagram in Figure 2. These five aluminium
7 plates could then be assembled together by using eight screws to produce inside dimensions
8 of 150 mm × 20 mm × 50 mm.

9

10 Figure 3 shows the whole procedure in terms of substrate preparation using coarse
11 aggregates. For the substrate preparation, graded or crushed rocks with sizes passing 50 mm
12 and retained on 20 mm were first trimmed using a trimming saw (as shown in Figure 3a) to
13 get an appropriately rectangular aggregate with one dimension being less than 20 mm. The
14 trimmed coarse aggregates are shown in Figure 3b. The aluminium mould was then
15 assembled and a release compound (Dow Corning DC4) used to grease the inside of the
16 mould surface to avoid it sticking to the epoxy resin used in the next step, as shown in
17 Figures 3c and d. An epoxy resin bonding material (Araldite), as shown in Figure 3e, was
18 prepared by mixing the two components together according to the required proportions. The
19 trimmed aggregates were assembled into the mould followed by filling the spaces in the
20 mould with the epoxy resin as shown in Figure 3f. The assembled mould was stored at room
21 temperature for 24 hours to allow the epoxy resin to cure. After 24 hours of curing, the mould
22 was disassembled and the cured sample tipped out, as shown in Figure 3g. Finally, the cured
23 sample was cut down the middle to get two substrates with a thickness no less than 10 mm, as
24 shown in Figure 3h.

25

1 3.2.2 Adhesion specimen fabrication

2

3 The aggregate substrates, including the standard aggregate substrates and composite
4 substrates using coarse aggregates, with dimensions of 150 mm × 20 mm × 10 mm were
5 prepared as previously described. They were then bonded to the aluminium peel arm using
6 bitumen as the adhesive layer. The thickness of the bitumen adhesive layer is controlled by
7 placing five wire spacers on the aggregate and results in a 0.25 mm film thickness. The
8 sample preparation consists of the following steps [17]:

9 1. Surface pre-treatment. Aggregate substrate was ground using sand paper to get a
10 smooth surface. The ground substrate and peel arm are then wiped gently using a damp
11 paper towel to remove any dust.

12 2. Pre-heating the aggregate and the bitumen. The aggregate and peel arm are then placed
13 in an oven at 150°C for 1 hour. Bitumen is preheated to 150°C prior to making the
14 joint.

15 3. Placing the sharp crack initiator. A release Polytetrafluoroethylene (PTFE) film of
16 dimensions 20 mm × 12 mm × 75 µm is placed on the aggregate surface at one end.

17 4. Five wire spacers with a length of 20 mm are placed on the aggregate. The diameter of
18 the wire controls the thickness of the bitumen (adhesive) layer.

19 5. The liquid bitumen is applied (at 150°C) evenly along the surface of the aggregate.

20 6. The preheated aluminium peel arm (of length 50 mm longer than the aggregate
21 substrate and of thickness 0.2 mm) is placed on the top of the bitumen layer.

22 7. Gentle pressure is applied on top of the joint to control the thickness of the bitumen
23 layer. The pressure should be uniformly distributed over the bond area. The excess
24 bitumen at the edges of the specimen was trimmed with a heated knife.

25 8. All specimens were stored at room temperature ready for further testing.

1
2
3
4
5
6
7
8
9
10
11
12
13
14
15
16
17
18
19
20
21
22
23
24
25

3.2.3 Moisture conditioning

The prepared aggregate-bitumen adhesion specimens were tested in the dry condition or after moisture-conditioned. Moisture was introduced into the aggregate-bitumen interface by submerging the completed specimens in distilled water at 20°C for 7 days or 14 days. During the conditioning period, moisture could reach the aggregate-bitumen interface and directly attack the bond. The specimens should be tested within 1 hour after removing them from the water bath.

3.2.4 Parameter evaluation

A universal testing machine (UTM) which can supply a constant rate of grip separation was used to measure the tensile force during the peel test. The sample was attached to a linear bearing to get a highly accurate and smooth motion. During testing, the free end of the peel arm was gripped by the UTM fixture and stretched up at the speed of 10 mm/min with the peel angle being maintained at 90°, as shown in Figure 4. The tensile force was recorded during the fracture development and the results used to calculate the fracture energy.

The achieved peel force was first used to calculate the uncorrected adhesive fracture energy, using Equation as follows:

$$G = \frac{P}{b}(1 - \cos \theta) \tag{1}$$

where P is the average peel force, b is the width of the adhesive surface and θ is the applied

1 peel angle.

2

3 Then, the corrected fracture energy is obtained by removing the energy associated with the
4 plastic bending of the peel arm:

5

$$6 \quad G_A = G - G_P \quad (2)$$

7

8 where G_A is the corrected fracture energy and G_P is the energy associated with the plastic
9 bending of the peel arm.

10

11 In order to calculate the fracture energy of the aggregate-bitumen bond, the mechanical
12 properties of the aluminium peel arm were first determined using the same tensile speed as
13 the peel test. In order to describe the elastic and plastic deformation of the peel arm, the
14 stress-strain curve should be fitted with a bi-linear or power law equation [19]. The purpose
15 of the bi-linear and power law curve fits is to get a number of parameters which are used to
16 calculate the fracture energy. The following parameters of the bi-linear model (Eq. 3) for the
17 peel arm were used for the plastic corrections as described in the following equation:

18

$$19 \quad \sigma = \sigma_y + \alpha E_1 (\varepsilon - \varepsilon_y) \quad (3)$$

20

21 where σ_y is yield stress and ε_y is the yield strain, E_1 is the elastic modulus of the peel arm, E_2
22 is the plastic modulus of the peel arm, n is the work hardening coefficient of the peel arm and
23 α is the ratio of plastic modulus to elastic modulus, E_2/E_1 .

24

25 The measured stress-strain curve was modelled using the bi-linear model and the parameters

1 gained from the fitting process are shown in Table 2. The value of the corrected fracture
2 energy was then calculated using large displacement beam theory.

3

4 4. Results

5

6 4.1 Mineralogy of aggregates

7

8 The scan images of the four aggregate surfaces obtained from MLA test are presented in
9 Figure 5 with one colors representing one type of mineral. From this figure it can be seen that
10 minerals in the granite samples (G1 and G2) exhibit considerable texture and the distribution
11 is more complex, while the limestone surfaces (L1 and L2) are simple with one dominant
12 mineral making up almost all of the mineral composition. The mineralogical compositions of
13 these four aggregates are shown in Table 3. As shown in this table, chlorite, albite and quartz
14 are the dominant minerals for these two granite aggregates with contents greater than 10%.
15 There are two other minerals, epidote and anorthite, detected in G1 and G2 respectively with
16 presences higher than 10%. For the limestone (L1 and L2) samples, calcite is the predominant
17 phase when compared to the other minerals present, with 96.98% and 99.48% by weight,
18 respectively. It is believed that the large proportion of the albite and quartz phases have the
19 potential to lead to moisture damage due to the poor adhesion between quartz and bitumen
20 [25].

21

22 4.2 Fracture energy calculation for both CSPT and standard peel test

23

24 The purpose of the peel test was to determine the fracture energy of aggregate-bitumen bonds
25 as a function of material type and moisture conditioning time. Results are presented for four

1 replicate tests performed on each aggregate-bitumen combination. The tensile force was
2 recorded by the UTM during testing and the tensile load versus displacement curve was
3 plotted. For the standard peel test, the tensile force tends to remain at an approximately
4 constant value after the initial stage. Normally, around 50 mm of constant crack propagation
5 region will be selected for average tensile force calculation and this procedure has been
6 presented in previous publications [17, 18].

7

8 In terms of the newly developed CSPT, the method to calculate the average tensile force
9 showed some difference in comparison with the standard peel test, with one type of specimen
10 (G2) being selected to illustrate this point, as shown in Figure 6. In the dry condition, as
11 shown in Figure 6a, the tensile force values were constant with the development of the
12 fracture. This means that the average tensile force could be calculated using the same
13 approach as the standard peel test. After moisture conditioning, the tensile force is not
14 constant and three obvious fluctuations occurred with the crack propagation, as shown in
15 Figure 6b. In this condition, the values in the fluctuations need to be removed and the
16 baseline of the curve used as the useful average tensile force. The average force of each
17 sample and the parameters in Table 2 were entered into the Microsoft excel macro IC Peel
18 software to calculate the fracture energy [26].

19

20 4.3 CSPT results

21

22 4.3.1 Fracture energy in dry condition

23

24 Specimens prepared with bitumen and the four coarse aggregates (L1, L2, G1 and G2) were
25 subjected to the CSPT. The aggregates were first combined together using epoxy resin and

1 the self-designed mould followed by preparing the peel test specimen, as described in Section
2 3.2.1 and 3.2.2. The tensile load and fracture energy of specimens before and after moisture
3 damage were evaluated based on the procedures in Sections 3.2.4 and 4.2.

4

5 Table 4 shows the average fracture energy and test variability (standard deviation) of
6 specimens before moisture conditioning with results being achieved with the newly
7 developed CSPT. The standard deviation suggests the test has low variability. From this table
8 it can be seen that all specimens have almost the same fracture energy in dry condition,
9 irrespective of which aggregate was used. Without moisture conditioning, a cohesive failure
10 occurred within the bulk of the bitumen, as shown in Figure 7. The fracture energy depended
11 on the cohesive bond in the bulk of the bitumen layer. This is why all aggregates show almost
12 the same fracture energy in the dry condition.

13

14 4.3.2 Failure behaviour after moisture conditioning

15

16 To simulate the effect of moisture on the bonding properties between bitumen and aggregate,
17 the whole specimen was submersed in water at 20°C for 7 days and 14 days. During that
18 time, moisture is able to reach the aggregate-bitumen interface in three different ways:
19 through the top and bottom of the aggregate, through the edge of aggregate-bitumen interface
20 and through the bitumen film. After moisture conditioning, specimens were removed from
21 the water bath and then subjected to the peel test within 1 hour.

22

23 In this research, the loading behaviour and failure surface of the two granite samples were
24 selected for detailed analyse as shown in Figure 8. It can be seen that these samples showed
25 different loading behaviour and failure surfaces due to the different moisture sensitivity of the

1 aggregates. The sample prepared with G1 aggregate showed mainly cohesive failure with
2 adhesive failure occurring at both edges of the specimen after 14 days of moisture
3 conditioning with the tensile load not decreasing significantly in comparison with the tensile
4 load in Figure 6a. In contrast, the failure surface of G2 is nearly completely adhesive and the
5 tensile load decreased significantly. There are also three obvious fluctuations (peaks) due to
6 the cohesive failure over the epoxy resin segments between two adjacent aggregates. From
7 this figure it can be seen that the tensile load accurately reflects the failure mode which
8 demonstrates that the composite substrate could be used for fracture energy evaluation.

9

10 4.3.3 Retained fracture energy

11

12 The effect of moisture on the bond strength could be captured using a single retained fracture
13 energy percentage as a more elegant and unified way of characterising aggregate-bitumen
14 bond strength. In general, the larger the magnitude of retained fracture energy of a joint, the
15 greater the resistance to failure from applied loading after moisture conditioning. The
16 retained fracture energy of specimens after 7 days and 14 days moisture conditioning were
17 calculated by dividing the conditioned fracture energy by the dry fracture energy, and the
18 results are shown in Figure 9. Because the materials used in CSPT are coarse aggregates used
19 in actual asphalt mixture field applications, the results are much more reliable in terms of
20 identifying a ‘good’ versus ‘bad’ moisture resistant mixture.

21

22 As shown in Figure 9, one effect of moisture on the aggregate-bitumen interface is the
23 reduction in fracture energy with different aggregates showing different values. The
24 significant difference in retained fracture energy could be explained by the water adsorption
25 properties and mineral composition of the aggregates. For G1 aggregate, the dominant

1 mineral phases, albite and quartz, are considered to be sensitive to moisture damage.
2 However, because of its lower moisture absorption (0.13%), it is hard for water to diffuse
3 through the aggregate to the aggregate-bitumen interface to weaken the bond. The other
4 granite aggregate G2 with higher moisture adsorption values had the lowest retained fracture
5 energy. This is not surprising as G2 aggregate has had a long history of very poor moisture
6 damage performance in the field [27]. In terms of the limestone aggregates (L1 and L2), both
7 showed good moisture resistance due to their dominant mineral phase (calcite) being able to
8 form a stable bond with bitumen even in the presence of water. The slightly lower result of
9 L1 could be attributing to its higher water adsorption (2.21%) in comparison with L2
10 (0.46%). On this basis, it is reasonable to state that the moisture sensitivity of aggregate-
11 bitumen bonds is not only controlled by the mineralogical compositions but the moisture
12 absorption of the aggregate should also be considered.

13

14 4.4 Standard peel test results

15

16 4.4.1 Fracture energy in dry condition

17

18 Table 5 shows the dry fracture energy values of aggregate-bitumen bonds based on the
19 standard peel test. In this test, the aggregate substrates were prepared from big aggregate
20 boulders. Before moisture conditioning, all specimens showed cohesive failure surface which
21 correlated well with the newly developed CSPT. It can be seen from this table that the
22 fracture energy of these four samples show similar values demonstrating the influence of
23 aggregate is minimised. Another finding is that the fracture energy values obtained from the
24 standard peel test are similar to those from the new CSPT, as shown in Table 4. This

1 indicates that the CSPT is able to correctly evaluate the fracture energy of aggregate-bitumen
2 bonds in the dry condition.

3

4 4.4.2 Failure behaviour after moisture conditioning

5

6 The specimens prepared based on the standard peel test were also subjected to moisture
7 conditioning following the procedures as shown in Section 3.2.3. After peel testing, the
8 loading behaviour and failure surfaces of G1 and G2 were selected to compare with the CSPT
9 results, as shown in Figure 10. It can be seen that the G1 specimen results in a higher loading
10 value in comparison with G2 identical to the trend found from the CSPT results in Figure 8.
11 The G1 specimen shows cohesive failure while the G2 specimen shows mostly adhesive
12 failure. From this figure it can be seen that the tensile load has a strong relationship with the
13 failure mode. For example, the tensile load value of G2 fluctuates according to the proportion
14 of cohesive/adhesive failure with cohesive failure tending to exhibit a higher tensile load
15 while adhesive failure results in a lower value.

16

17 With the aim of directly comparing the measurements made with CSPT and the standard peel
18 test, the loading behaviour of the G1 and G2 specimens obtained from these two tests were
19 plotted in Figure 11. From this figure it can be seen that by using the same aggregate, these
20 two different tests show similar loading results thus demonstrating that the newly developed
21 CSPT could obtain similar loading behaviour as determined with the standard peel test.

22

23 4.4.3 Retained fracture energy

24

1 After moisture damage, the retained fracture energy of the four samples was defined as the
2 ratio of fracture energy after moisture conditioning to the one before moisture conditioning.
3 Plotted against time, the retained energy could be used to characterise the moisture resistance
4 with higher values suggesting better moisture resistance properties. Figure 12 shows plots of
5 retained fracture energy with conditioning time for the four specimens obtained from the
6 standard peel test. From this figure it can be seen that these four specimens showed different
7 retained fracture energy with the passage of time. This could be explained in aspects of
8 moisture absorption and mineralogical composition of aggregates as described in Section
9 4.3.3. It is noticeable that the four specimens showed the same ranking in terms of the
10 retained fracture energy as the results from CSPT (Figure 9). It can therefore be concluded
11 that the newly developed CSPT can be considered to be a reliable alternative to the standard
12 peel test to identify the moisture sensitivity of aggregate-bitumen bonds.

13

14 4.5 Correlation between CSPT and standard peel test

15

16 To quantify the relationship between the CSPT and the standard peel test, the retained
17 fracture energies from the two tests were plotted against each other. Figure 13 shows the plot
18 depicting the relationship between retained fracture energy, including 7 days and 14 days,
19 obtained from the CSPT and those from the standard peel test. It can be seen that the eight
20 results are all located on one trend line demonstrating that the CSPT and the standard peel
21 test give almost the same evaluation in terms of the moisture susceptibility of the different
22 aggregate-bitumen systems. It should be noted that in general the CSPT results are lower in
23 comparison with the standard peel test. The results suggest that the newly developed CSPT is
24 reliable in term of moisture damage evaluation and provides a more practical means of

1 assessing the moisture damage performance of aggregate-bitumen systems using actual
2 asphalt mixture coarse aggregates rather than large aggregate boulders.

3

4 5. Conclusions

5

6 The following conclusions were deduced based on the results presented in this study:

- 7 • As shown by both the CSPT and standard peel test, the aggregate properties do not
8 influence the bonding strength of aggregate-bitumen combinations in the absence of
9 moisture when the dominant failure mechanism is cohesive. Under these dry conditions
10 the samples from both tests showed similar fracture energy values.
- 11 • The magnitude of the fracture energy in the presence of water was found to be
12 aggregate type dependent rather than bitumen dependent with failure being adhesive in
13 nature. The tests demonstrated that the physico-chemical properties of the aggregates
14 play a fundamental and significant role in the development of the moisture damage
15 performance of aggregate-bitumen bonds.
- 16 • The newly developed CSPT was found to be effective in characterising the moisture
17 resistance of the aggregate-bitumen bonds.
- 18 • The retained fracture energy results were shown to be sensitive to moisture
19 conditioning and the moisture resistance could be explained by the moisture adsorption
20 and mineralogical compositions of the aggregates. Limestone tended to have better
21 resistance to moisture damage than granite with the same moisture adsorption.
22 Furthermore, in terms of similar mineralogical compositions, lower moisture adsorption
23 resulted in better moisture resistance.
- 24 • The newly developed CSPT and the standard peel test showed the same ranking in
25 terms of the moisture damage evaluation demonstrating that the CSPT is a reliable and

1 feasible design to assess the moisture damage performance of aggregate-bitumen
2 systems.

3

4 Acknowledgements

5 The authors acknowledge the assistance of the following Nottingham Transportation
6 Engineering Centre personnel: Richard Blackmore, Lawrence Pont and Jonathan Watson for
7 material testing.

8

9 References

- 10 1. <https://www.gov.uk/government/statistics/road-lengths-in-great-britain-2014>
- 11 2. Airey G. and Wu J. The influence of aggregate interaction and aging procedure on
12 bitumen aging [J]. Journal of Testing and Evaluation, 2009, 37(5): 1-8.
- 13 3. Qiao Y., Flintsch G., Dawson A. and Parry T. Examining Effects of Climatic Factors
14 on Flexible Pavement Performance and Service Life [J]. Transportation Research
15 Record: Journal of the Transportation Research Board, 2013 (2349): 100-107.
- 16 4. Annual Local Authority Road Maintenance (ALARM) Survey 2014. Asphalt Industry
17 Alliance,
18 [http://www.asphaltindustryalliance.com/images/library/files/ALARM_Survey_2014.](http://www.asphaltindustryalliance.com/images/library/files/ALARM_Survey_2014.pdf)
19 pdf][accessed 03.07.14].
- 20 5. Airey G.D., Choi Y.K., Collop A.C., Moore A.J.V. and Elliott R.C. Combined
21 Laboratory Ageing/Moisture Sensitivity Assessment of High Modulus Base Asphalt
22 Mixtures (With Discussion) [J]. Journal of the Association of Asphalt Paving
23 Technologists, 2005, 74: 307-346.
- 24 6. Kim Y.R., Little D.N. and Lytton R.L. Effect of moisture damage on material
25 properties and fatigue resistance of asphalt mixtures. Journal Transportation Research

- 1 Record (TRB) 2004; 1891: 48–54.
- 2 7. Mehrara A. and Khodaii A. A review of state of the art on stripping phenomenon in
3 asphalt concrete [J]. *Construction and Building Materials*, 2013, 38: 423-442.
- 4 8. Apeageyi A.K., Grenfell J.R.A. and Airey G.D. Observation of reversible moisture
5 damage in asphalt mixtures [J]. *Construction and Building Materials*, 2014, 60: 73-80.
- 6 9. Lu Q. Investigation of conditions for moisture damage in asphalt concrete and
7 appropriate laboratory test methods [D]. University of California Transportation
8 Center, 2005.
- 9 10. Grenfell J., Ahmad N., Liu Y., Apeageyi A., Large L and Airey G. Assessing asphalt
10 mixture moisture susceptibility through intrinsic adhesion, bitumen stripping and
11 mechanical damage [J]. *Road Materials and Pavement Design*, 2014, 15(1): 131-152.
- 12 11. Grenfell J., Ahmad N., Airey G.D., Collop A.C. and Elliott R. Optimising the
13 moisture durability SATS conditioning parameters for universal asphalt mixture
14 application. *International Journal of Pavement Engineering* 2012; 13(5): 433–50.
- 15 12. Fromm H.J. The mechanisms of asphalt stripping from aggregates surfaces. *Journal of*
16 *the Association of Asphalt Paving Technologists* 1974, vol. 43, pp. 191-223.
- 17 13. Mo L., Huurman M., Wu S. and Molenaar A.A.A. Ravelling investigation of porous
18 asphalt concrete based on fatigue characteristics of bitumen–stone adhesion and
19 mortar [J]. *Materials & Design*, 2009, 30(1): 170-179.
- 20 14. Whiteoak D. *The shell bitumen handbook* [M]. Shell Bitumen UK, 1990.
- 21 15. Liu Y., Apeageyi A., Ahmad N., Grenfell G. and Airey G. Examination of moisture
22 sensitivity of aggregate–bitumen bonding strength using loose asphalt mixture and
23 physico-chemical surface energy property tests [J]. *International Journal of Pavement*
24 *Engineering*, 2014, 15(7): 657-670.

- 1 16. Airey G.D. and Choi Y.K. State of the art report on moisture sensitivity test methods
2 for bituminous pavement materials [J]. Road Materials and Pavement Design 2002,
3 3(4): 355-372.
- 4 17. Zhang J., Airey G.D. and Grenfell J.R.A. Experimental evaluation of cohesive and
5 adhesive bond strength and fracture energy of bitumen-aggregate systems[J].
6 Materials and Structures, 2015: 1-15.
- 7 18. Zhang J., Apegyei A.K., Airey G.D. and Grenfell J.R.A.. Influence of aggregate
8 mineralogical composition on water resistance of aggregate-bitumen adhesion [J].
9 International Journal of Adhesion and Adhesives, 2015, 62: 45-54.
- 10 19. Blackman B.R.K., Cui S., Kinloch A.J. and Taylor A.C. The development of a novel
11 test method to assess the durability of asphalt road-pavement materials. International
12 Journal of Adhesion and Adhesives 2013; 42: 1-10.
- 13 20. Zhang J., Apegyei A.K. and Airey G.D. Effect of Aggregate Composition on
14 Moisture Sensitivity of Aggregate-Bitumen Bonds, Transportation Research Board
15 94th Annual Meeting. 2015 (15-0999).
- 16 21. Kawashita L.F., Moore D.R. and Williams J.G. Analysis of peel arm curvature for the
17 determination of fracture toughness in metal-polymer laminates. Journal of materials
18 science 2005; 40(17): 4541-4548.
- 19 22. Horgnies M., Willieme P. and Gabet O. Influence of the surface properties of
20 concrete on the adhesion of coating: Characterization of the interface by peel test and
21 FT-IR spectroscopy. Progress in Organic Coatings 2011; 72(3): 360-379.
- 22 23. Leforestier E., Darque-Ceretti E., Peiti D. and Bolla M. Peeling and characterisation
23 of the carbon fibre-based radicular adhesive anchorage interface, International Journal
24 of Adhesion and Adhesives 2007; 27(8): 629-635.

- 1 24. Horgnies M., Darque-Ceretti E., Fezai H. and Felder E. Influence of the interfacial
2 composition on the adhesion between aggregates and bitumen: Investigations by
3 EDX, XPS and peel tests. *International Journal of Adhesion and Adhesives* 2011;
4 31(5): 238–247.
- 5 25. Apeagyei A.K., Grenfell J. and Airey G.D. Moisture-induced strength degradation of
6 aggregate–asphalt mastic bonds. *Road Materials and Pavement Design* 2014; 15(1):
7 239-262.
- 8 26. IC Peel software. <http://www3.imperial.ac.uk/meadhesion/testprotocols/peel>.
9 Imperial College London. Accessed 14 March 2013.
- 10 27. Airey G.D., Collop A.C., Zoorob S.E. and Elliott R.C. The influence of aggregate,
11 filler and bitumen on asphalt mixture moisture damage. *Construction and Building*
12 *Materials* 2008, 22(9): 2015-2024.

13
14
15
16
17
18
19
20
21
22

Figures



Figure 1. Aggregate substrate and coarse aggregates: (a) substrate must be prepared from large boulders, while (b) coarse aggregates are readily available in most labs.

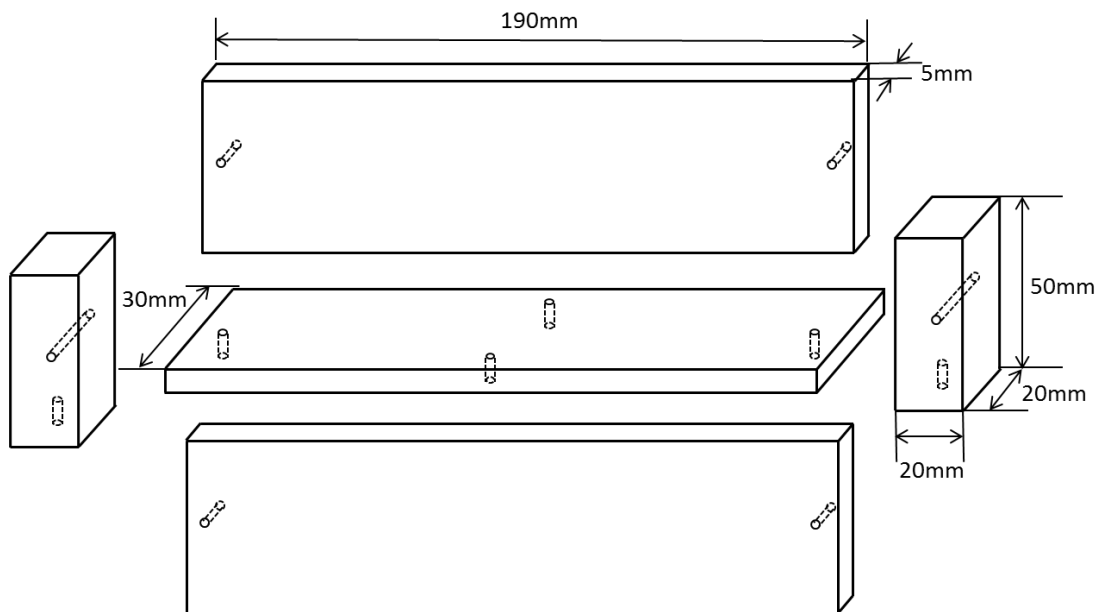
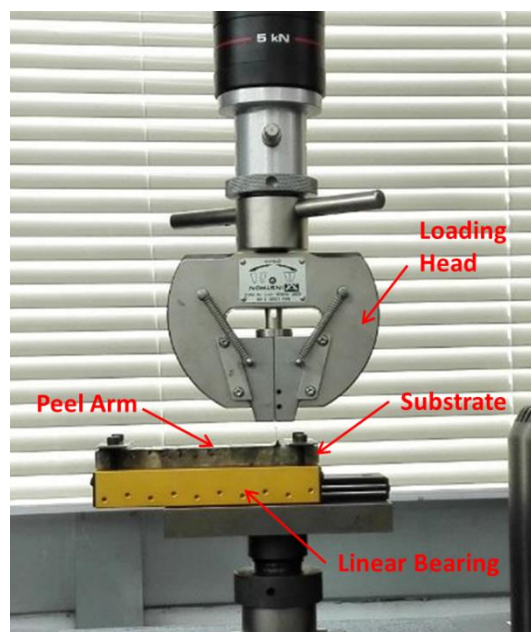

Figure 2. Schematic of the aluminium mould used for composite substrate preparation



1 Figure 3. Procedures for aggregate substrate preparation: (a) trim saw, (b) aggregates after
 2 trimming, (c) release compound, (d) assembled mould, (e) epoxy resin, (f) combine trimmed
 3 aggregates in the mould and fill the gaps with epoxy resin, (g) cured composite aggregate, (h)
 4 composite substrate used for peel test.
 5
 6
 7
 8



9
 10
 11
 12
 Figure 4. Details of peel test equipment

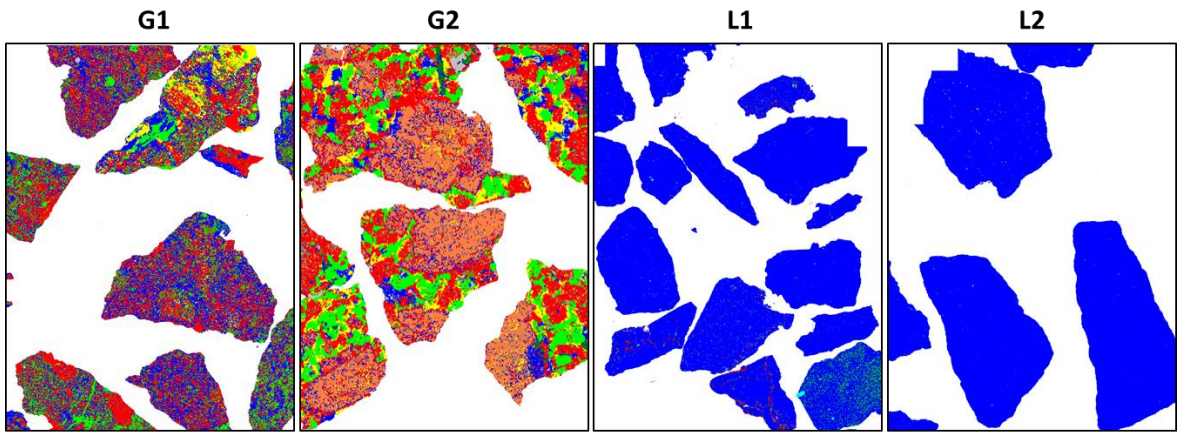

1
2
3
4
5
6
7

Figure 5. Scanned images of aggregate surfaces with one colors representing one type of mineral

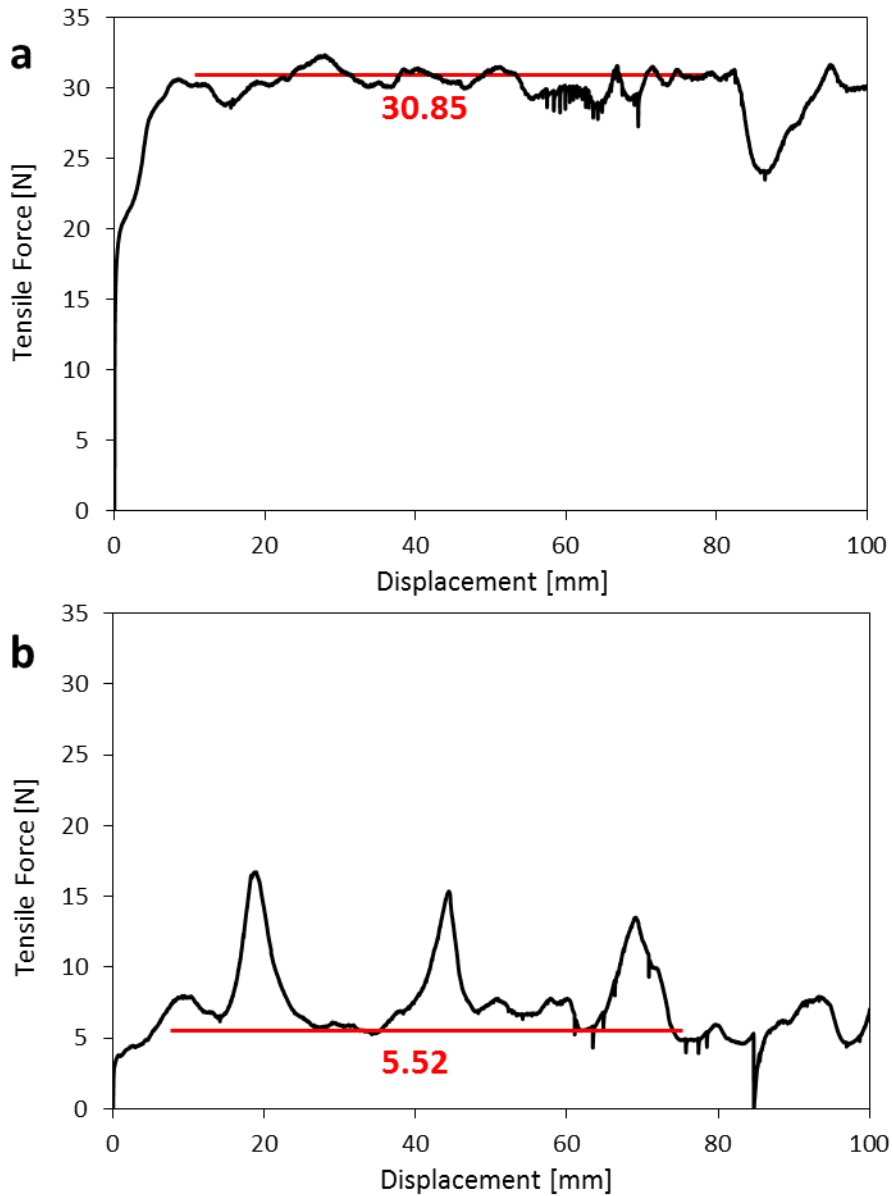

1
 2 Figure 6. Measured tensile stress-strain curve of: (a) B1-G2 in dry condition using CSPT and
 3 (b) B1-G2 after 14 days conditioning using CSPT. The three fluctuations presented in Figure
 4 6b are due to the epoxy resin segments between two aggregates resulting in high bond
 5 strength with bitumen even after moisture damage.
 6
 7
 8
 9



10
 11 Figure 7. Failure surface of specimens prepared with G2 aggregates in dry condition
 12

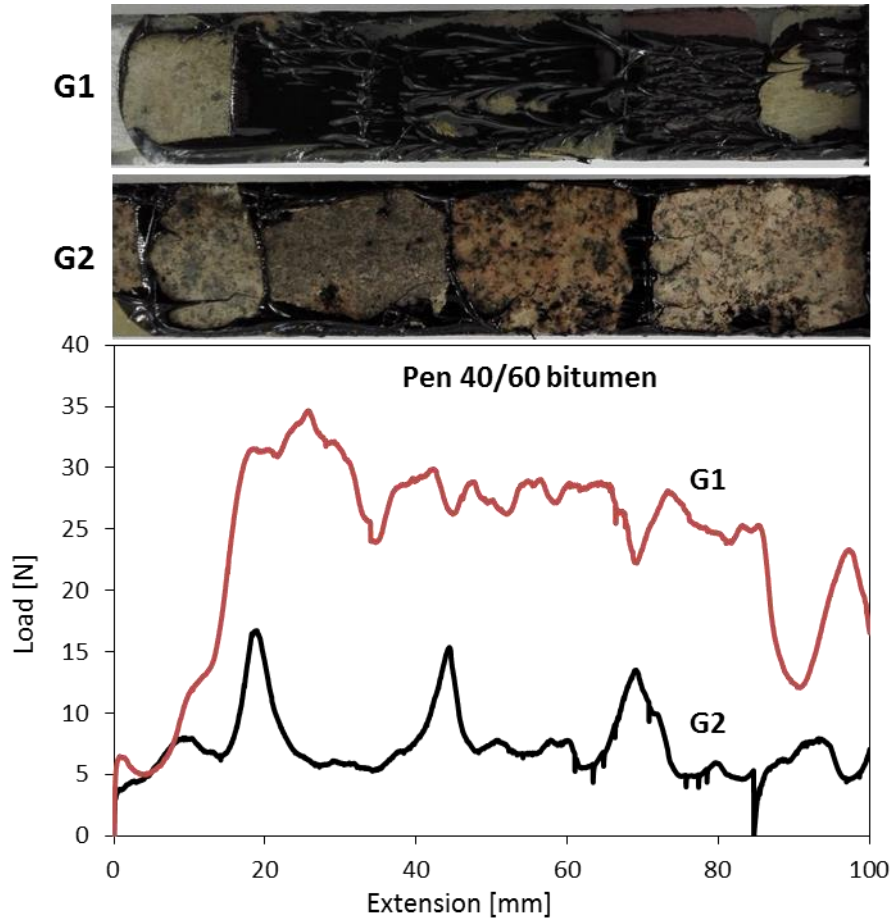

1
2
3
4
5
6
7
Figure 8. Failure surfaces and loading behaviour of two specimens (G1 and G2) after 14 days of moisture conditioning using CSPT

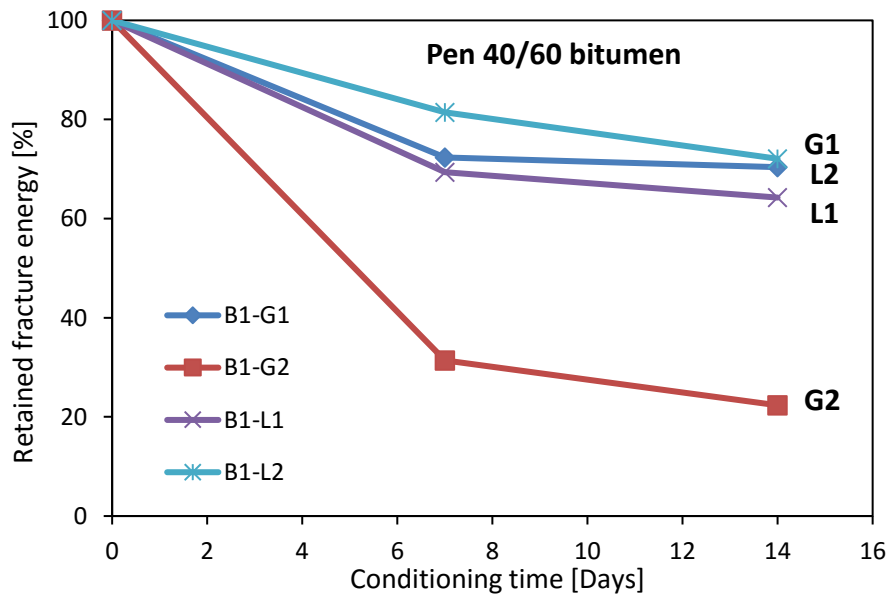

8
9
10
Figure 9. Retained fracture energy with respect to moisture damage achieved from CSPT

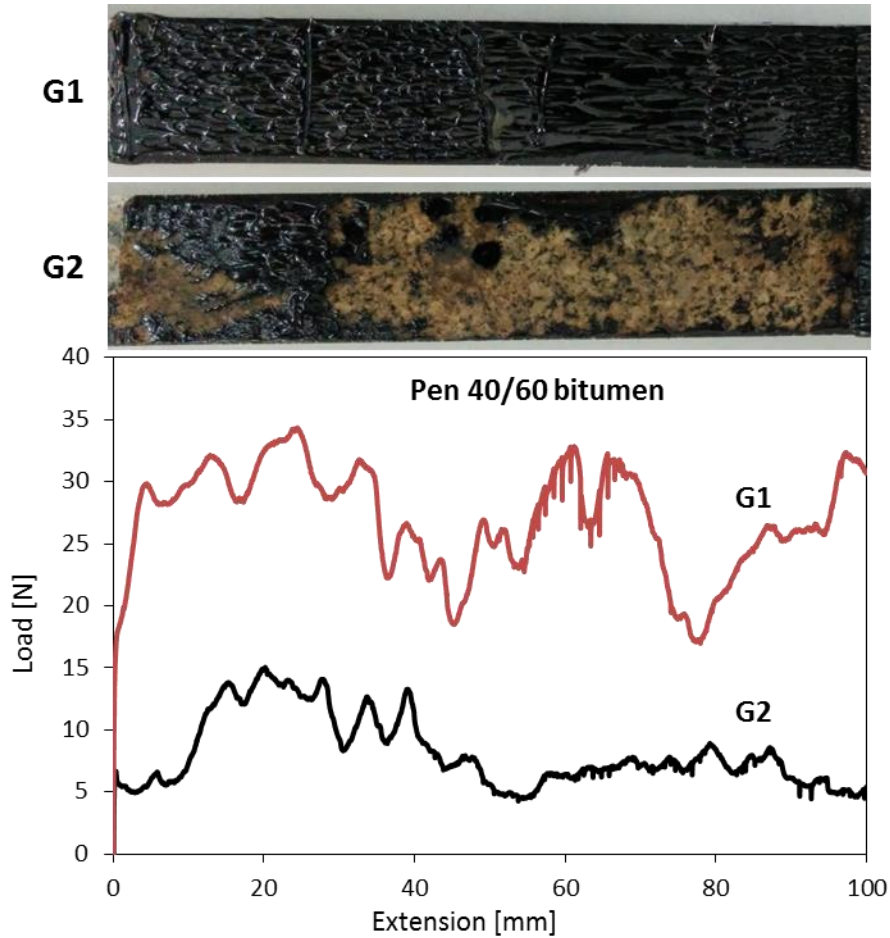

1
2
3
4
5
6
7

Figure 10. Failure surfaces and loading behaviour of two samples (G1 and G2) after 14 days of moisture conditioning using standard peel test

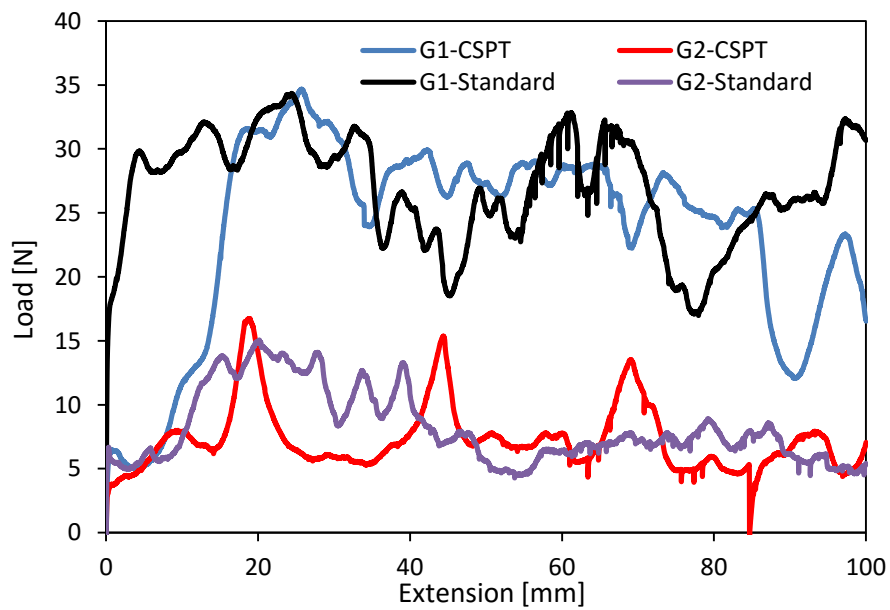

8
9
10

Figure 11. Loading behaviour of two samples (G1 and G2) after 14 days of moisture conditioning obtained using both standard peel test and CSPT

1

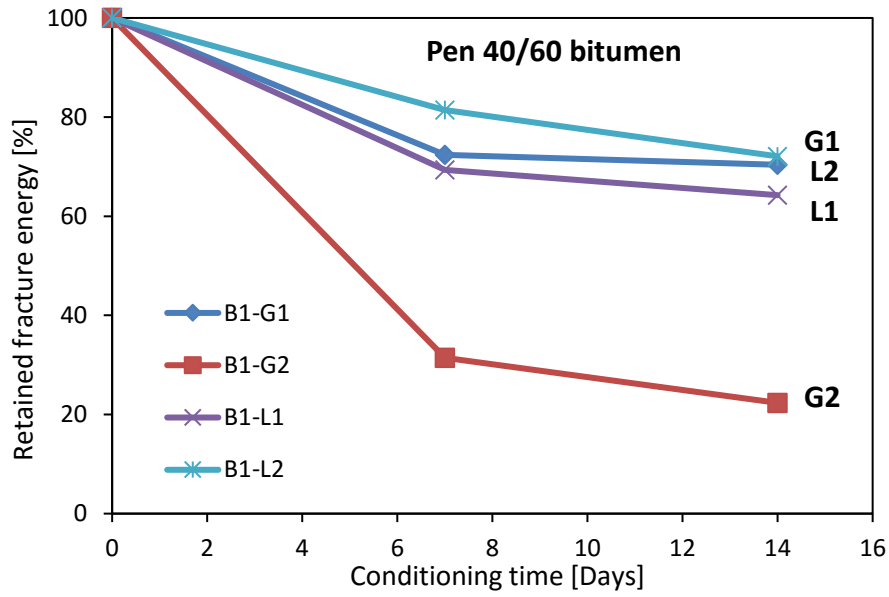

2

3

Figure 12. Retained fracture energy with respect to moisture damage achieved from standard peel test

4

5

6

7

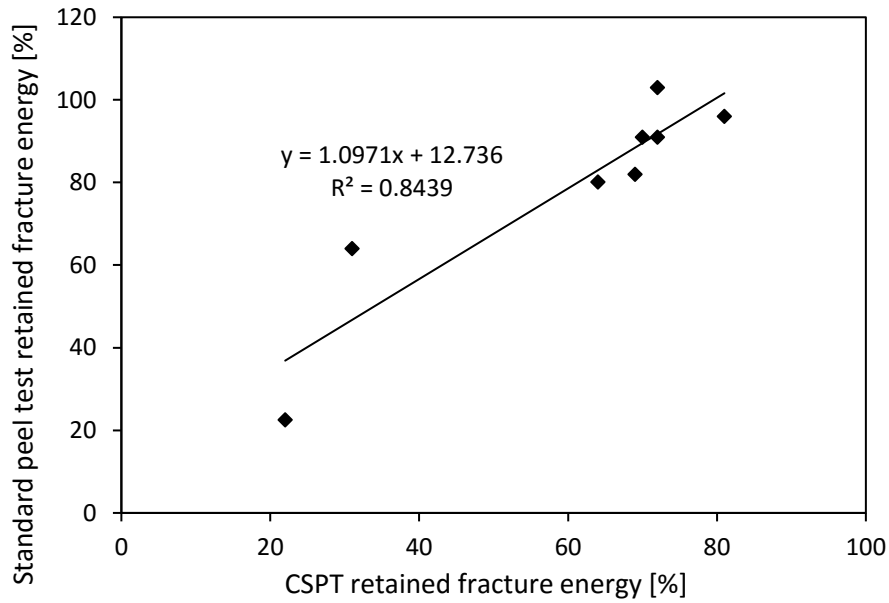

8

9

Figure 13. Plots of CSPT retained fracture energy and standard peel test retained fracture energy of specimens prepared with B1 bitumen showing good agreement between these two tests

10

11

12

13

14

15

16

17

1 **Tables**

2

3 Table 1. Water absorption of related aggregates

Aggregates	L1	L2	G1	G2
Water absorption %	2.21	0.46	0.13	0.47

4

5

6 Table 2. Plastic bending parameters of the peel arm based on bi-linear model fit

Parameters	Quantity
Low strain modulus, E_1	58.2 GPa
High strain modulus, E_2	1.25 GPa
Yield strain, ϵ_y	0.046 %
$\alpha (E_2/E_1)$	0.0215
Yield stress, σ_y	26.4MPa

7

8

9

10

11 Table 3 Mineral composition of aggregates identified by MLA analysis

Mineral type	Composition (Wt%)			
	G1	G2	L1	L2
Chlorite	31.53	13.52	-	-
Albite	27.13	32.73	-	-
Quartz	19.11	15.86	0.49	0.23
Epidote	11.11	1.37	-	-
K-feldspar	4.82	9.64	-	-
Muscovite	2.39	3.43	-	-
Hornblende	1.88	2.57	-	-
Biotite	0.99	0.34	-	-
Other	0.74	1.91	0.30	0.05
Calcite	0.20	0.08	96.98	99.48
Anorthite	0.10	18.54	-	-
Dolomite	-	-	1.30	0.13
Clay	-	-	0.93	0.10
Total	100	100	100	100

12

13

14

1 Table 4. Dry fracture energy (J/m^2) of aggregate-bitumen bonds in the dry state at 20°C using
2 the newly developed CSPT.

Methods	Mean \pm 1 SD (J/m^2)			
	L1	L2	G1	G2
CSPT	1003 \pm 6.5	982 \pm 7.6	991 \pm 9.1	992 \pm 25.5

3 Note: SD = standard deviation

4

5

6 Table 5. Dry fracture energy (J/m^2) of aggregate-bitumen bonds in the dry state at 20°C using
7 the standard peel test.

Methods	Mean \pm 1 SD (J/m^2)			
	L1	L2	G1	G2
Standard peel test	988 \pm 29.7	981 \pm 29.4	1015 \pm 6.4	1012 \pm 16.5

8 Note: SD = standard deviation

9

10