

Wave propagation in pressurised composite structures with frequency band gap behaviour

T. Ampatzidis¹, D. Chronopoulos¹

¹ The University of Nottingham, Faculty of Engineering
University Park, Nottingham, NG7 2RD, United Kingdom
e-mail: emxta3@nottingham.ac.uk

Abstract

In engineering there are numerous examples of structures, such as train rails and airplane fuselages, that present periodicity in their geometry or mechanical properties. It has been observed that this periodicity leads to banded frequency response after excitation. These band gaps can be engineered to isolate noise and vibrations of the periodic structure.

In this paper an infinite composite sandwich beam with hollow and pressurised core cells as periodic band gap inducing factors was examined. Wave finite element (WFE) method was used to predict the effect of pressured core cells periodicity on wave propagation and band gaps generation. Three low order finite elements (FE) models were produced using commercially available FE software package. These models consisted of a small section of the simple sandwich beam with homogenous core, with hollow core and with pressurised hollow core.

1 Introduction

Periodic structures consist of infinite assembly of identical elements, usually called cells, joined in an identical manner. These structures, also called *banded* structures, have been subject of research for more than a century. Floquet [1] was the first to publish research on periodic structures, where he studied 1D Mathieu's equation. His work was followed by Rayleigh [2], who arrived at a form of Floquet's theorem. In this century, Mead firstly introduced Wave Finite Elements (WFE) Method in [3] which is based on Brillouin's periodicity theory (PT) [4] and Floquet's and Bloch's theorems. In [5] his work on wave propagation in periodic structures was reviewed.

Periodic structures exhibit *band-gaps*, where wave propagation is significantly attenuated. Due to this attenuation and their potentials to passively damp vibration, numerous researches have been published examining periodic structures' banded frequency response. Some of the most important work are Ruzzene's et al. [6, 7] and Hussein's et al. [8, 9]. Ruzzene et al. focused on the control of wave propagation and banded behaviour, firstly in sandwich composite beams with periodic auxetic core [6] and then in 2D sandwich plate with periodic honeycomb [7]. In both works it was proved that banded behaviour can be controlled by changing parameters like the length ratio of the periodic cells of the core. Hussein et al. derived dispersion relations for periodic materials and examined the analysis [8] and design [9] of them. Based on these works, Liu et al. [10] produced a research focusing on the wave motion and banded response of four different types of periodicity in 1D beams. In addition to this work, Wu et al. [11] examined the banded behaviour of sandwiches with corrugated core, focusing on the geometry of the core and Chen et al. [12] examined the wave propagation in sandwich with periodic core. In the latter work, two different materials periodically forming the core of the sandwich were examined. WFE method has, also, been used to examine the banded behaviour of a periodic beam in [13].

In this paper two versions of an infinite composite sandwich beams were modelled and their wave dispersion

curves were examined. The first one's core was homogenous, while the second one's was periodically hollow inducing banded behaviour. For the second one a pre-stressed model was examined, with pressure applied on the skins in the hollow part of the core.

2 The one dimensional WFE method

2.1 Description of the method

In this work an infinite composite sandwich beam was examined. An ANSYS FE model of a small segment of the beam was created, whose length was L_x . This area was meshed with the only additional constraint that the DOFs and the numbering of the nodes on the left and right side ought to be identical [15]. The length of the segment, L_x , should not be too large or too small compared to the shortest wavelength so that the accuracy of the analysis is reliable [16]. According to a conventional FE analysis, the equation of the motion of the section is

$$[\mathbf{K} - \omega^2 \mathbf{M}] \mathbf{q} = \mathbf{f} \quad (1)$$

where \mathbf{K} and \mathbf{M} are the stiffness and mass matrices, respectively, \mathbf{f} is the vector of the nodal forces and \mathbf{q} the vector of the nodal DOFs. Damping can, also, be included in the analysis whether with \mathbf{K} being complex or as a viscous damping matrix \mathbf{C} . Dynamic stiffness matrix $\mathbf{D} = \mathbf{K} - \omega^2 \mathbf{M}$ is partitioned as in equation 2 in order to reflect the influence of internal, left and right nodes on the wave propagation (no external forced on the interior nodes):

$$\begin{bmatrix} \tilde{\mathbf{D}}_{II} & \tilde{\mathbf{D}}_{IL} & \tilde{\mathbf{D}}_{IR} \\ \tilde{\mathbf{D}}_{LI} & \tilde{\mathbf{D}}_{LL} & \tilde{\mathbf{D}}_{LR} \\ \tilde{\mathbf{D}}_{RI} & \tilde{\mathbf{D}}_{RL} & \tilde{\mathbf{D}}_{RR} \end{bmatrix} \begin{Bmatrix} \mathbf{q}_I \\ \mathbf{q}_L \\ \mathbf{q}_R \end{Bmatrix} = \begin{Bmatrix} \mathbf{0} \\ \mathbf{f}_L \\ \mathbf{f}_R \end{Bmatrix} \quad (2)$$

Since in our case the models included internal nodes, the appropriate condensation as described in [15] was used. After the condensation, equation 2 can be written as

$$\begin{bmatrix} \mathbf{D}_{LL} & \mathbf{D}_{LR} \\ \mathbf{D}_{RL} & \mathbf{D}_{RR} \end{bmatrix} \begin{Bmatrix} \mathbf{q}_L \\ \mathbf{q}_R \end{Bmatrix} = \begin{Bmatrix} \mathbf{f}_L \\ \mathbf{f}_R \end{Bmatrix} \quad (3)$$

where

$$\begin{aligned} \mathbf{D}_{LL} &= \tilde{\mathbf{D}}_{LL} - \tilde{\mathbf{D}}_{LI} \tilde{\mathbf{D}}_{II}^{-1} \tilde{\mathbf{D}}_{IL}, & \mathbf{D}_{LR} &= \tilde{\mathbf{D}}_{LR} - \tilde{\mathbf{D}}_{LI} \tilde{\mathbf{D}}_{II}^{-1} \tilde{\mathbf{D}}_{IR}, \\ \mathbf{D}_{RL} &= \tilde{\mathbf{D}}_{RL} - \tilde{\mathbf{D}}_{RI} \tilde{\mathbf{D}}_{II}^{-1} \tilde{\mathbf{D}}_{IL}, & \mathbf{D}_{RR} &= \tilde{\mathbf{D}}_{RR} - \tilde{\mathbf{D}}_{RI} \tilde{\mathbf{D}}_{II}^{-1} \tilde{\mathbf{D}}_{IR} \end{aligned} \quad (4)$$

According to Floquet's theorem, the equation that relates the displacements on the two edges of the section is [13]:

$$\mathbf{q}_R = \lambda \mathbf{q}_L, \quad \mathbf{f}_R = -\lambda \mathbf{f}_L, \quad (5)$$

where $\lambda = e^{-ikL_x}$, with k being the wavenumber. Equation 3 is rearranged:

$$\lambda \begin{Bmatrix} \mathbf{q}_L \\ \mathbf{f}_L \end{Bmatrix} = \mathbf{T} \begin{Bmatrix} \mathbf{q}_L \\ \mathbf{f}_L \end{Bmatrix}, \quad (6)$$

where

$$\mathbf{T} = \begin{bmatrix} -\mathbf{D}_{LR}^{-1}\mathbf{D}_{LL} & \mathbf{D}_{LR}^{-1} \\ -\mathbf{D}_{RL} + \mathbf{D}_{RR}\mathbf{D}_{LR}^{-1}\mathbf{D}_{LL} & -\mathbf{D}_{RR}\mathbf{D}_{LR}^{-1} \end{bmatrix} \quad (7)$$

is the transfer matrix. The transfer matrix \mathbf{T} depends only on the dynamic stiffness of the section. It has been shown [15] that the eigenvalues of \mathbf{T} are defined such that

$$\begin{aligned} |\lambda_j| &\leq 1, \\ \operatorname{Re}\{\mathbf{f}_L^H \dot{\mathbf{q}}_L\} &= \operatorname{Re}\{i\omega \mathbf{f}_L^H \mathbf{q}_L\} < 0 \quad \text{if } |\lambda_j| = 1. \end{aligned} \quad (8)$$

These eigensolutions come in two sets: (λ_j, ϕ_j^+) and $(1/\lambda_j, \phi_j^-)$ and represent n positive-going ($|\lambda_j| < 1$) and n negative-going ($|\lambda_j| > 1$) wave types, respectively, where n is the number of DOFs on each side of the section.

2.2 Postprocessing

The eigenvalues are complex numbers and can be written as [17]

$$\lambda_j = e^{-\mu_j L_x} e^{-ik_j L_x} \quad (9)$$

where $i = \sqrt{-1}$, $\mu \in \mathbb{R}$ stands for the change in amplitude and $k \in \mathbb{R}$ stands for the change in phase, which is generally known as wavenumber. Equation 9 can be written

$$-\frac{\ln \lambda_j}{L_x} = \mu_j + ik_j \quad (10)$$

Damping being absent, propagating waves' amplitude remains constant, which is given by $|\lambda_j| = 1$ and $\mu_j = 0$ and $\lambda_j = e^{-ikL_x}$, since $|e^{ix}| = 1 \quad \forall x \in \mathbb{R}$. The relation $\mu_j = 0$ was used as guide to get the propagating waves. For the non-propagating waves, μ_j was examined.

2.3 Stress stiffening

As in this work a scenario of pre-stressed structure was examined, pre-stress stiffness matrix \mathbf{K}_s had to be calculated. Considering that a static analysis had been solved, the updated stiffness matrix was calculated \mathbf{K} [14]:

$$\mathbf{K} = \mathbf{K}_0 + \mathbf{K}_s \quad (11)$$

where \mathbf{K}_0 the original element stiffness matrix and:

$$\mathbf{K}_s = \iiint \mathbf{G}^T \tau \mathbf{G} \, dx \, dy \, dz \quad (12)$$

where \mathbf{G} is a matrix of shape function derivatives and τ is a matrix of the current Cauchy (true) stresses σ in the global Cartesian system.

The updated matrix \mathbf{K} was then used in WFEM to get the wavenumbers and eigenvectors of the pre-stressed structure.

3 Numerical results

In this work two different models were examined: one infinite composite sandwich beam with fully homogenous core (Fig.1) and one with periodically hollow core (Fig.2). The latter beam was, also, examined in pre-stressed condition, with $10bar$ pressure applied on the skins in the hollow part of the core (Fig.3). The mechanical characteristics of each material used in the models are listed in Table 1, where E_i is the modulus of elasticity in direction i , ν_{ij} is the Poisson's ratio for i and j being the directions of extension and contraction, respectively, ρ is the density and G_{ij} is the shear modulus of elasticity in direction j on the plane whose normal is in direction i . In Fig.4 z axis is depicted. ANSYS 14.0 was used during the FE modelling. Linear 8-node ANSYS SOLID45 solid element was chosen for the segment's meshing, which comprises a 3D displacement field and three degrees of freedom per node (translations in the x , y , and z directions) [14]. All three models had the same core ($h_c = 10mm$) and skin thickness ($h_s = 1mm$) and the hollow part of the core was $L_h = 2cm$ long. The sandwich cell was $L_x = 8cm$ long and each element was $L_e = 1cm$. The beam's width was $2cm$.

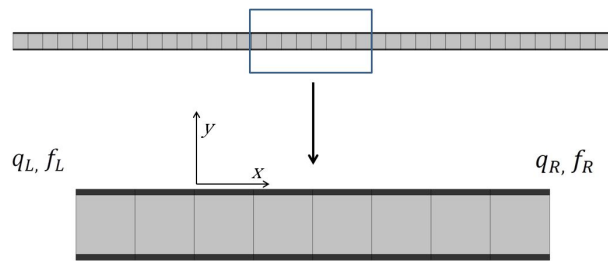

Figure 1: Infinite beam and cell with full homogenous core

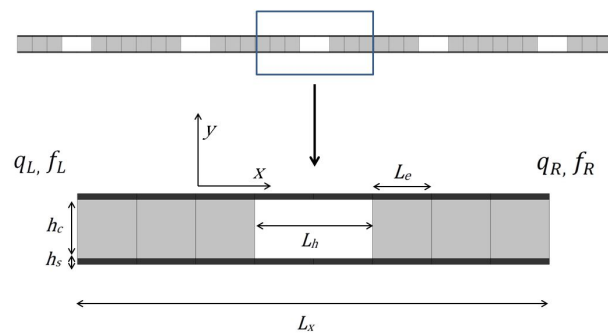

Figure 2: Infinite beam and cell with periodically hollow core

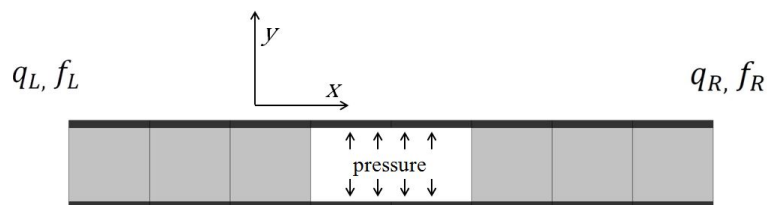

Figure 3: Modelled cell of the periodically hollow core beam with pressure applied on the skins

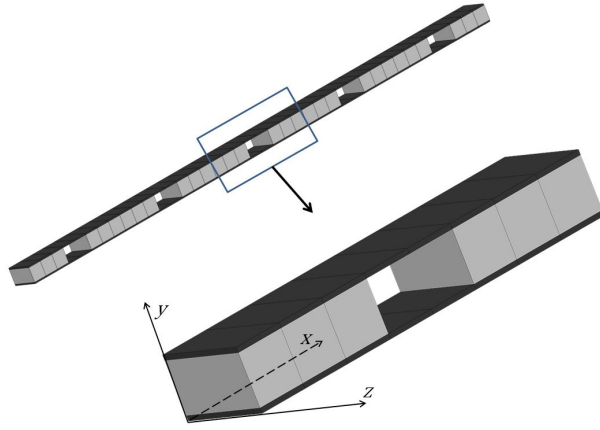

Figure 4: Infinite beam and the modelled cell

Material I	Material II
$\rho = 1870kg/m^3$	$\rho = 110kg/m^3$
$E_x = 60e9Pa$	$E_x = 145e6Pa$
$E_y = 40e9Pa$	$E_y = 145e6Pa$
$E_z = 60e9Pa$	$E_z = 145e6Pa$
$\nu_{xy} = 0.4$	$\nu_{xy} = 0.45$
$\nu_{yz} = 0.4$	$\nu_{yz} = 0.45$
$\nu_{xz} = 0.25$	$\nu_{xz} = 0.45$
$G_{xy} = 1.2e9Pa$	$G_{xy} = 50e6Pa$
$G_{yz} = 1.2e9Pa$	$G_{yz} = 50e6Pa$
$G_{xz} = 3.6e9Pa$	$G_{xz} = 50e6Pa$

Table 1: Material properties

3.1 Results

In Fig.5 the wavenumber curves of all three models are depicted and in Fig.6 the band gaps of the banded ones are depicted. The results are of the same nature with the ones in [6], [10] and [12], where infinite periodic beams were examined. As it was expected, the hollow core sandwich beam exhibits band gaps in the following frequency bands: $1184Hz - 2252Hz$, $2940Hz - 4756Hz$ and $6800Hz - 7572Hz$. As it is commented in [6], the discontinuity in the core of the sandwich beam along the beam's length represents a source of impedance mismatch, which is responsible for the existence of the band-gaps. In the same figure we can see that the frequency band gaps exhibited by the pressurised beam are slightly different than the non-pressurised one: $1172Hz - 2248Hz$, $2924Hz - 4740Hz$ and $6784Hz - 7560Hz$. This difference can be seen in Fig.7. This can be explained by the local pre-stress effect on the skins due to the applied pressure. The results reveal the potential for these two band gap inducing factors to be exploited so that the wave propagation in a sandwich beam can be controlled, as it is suggested in the following section.

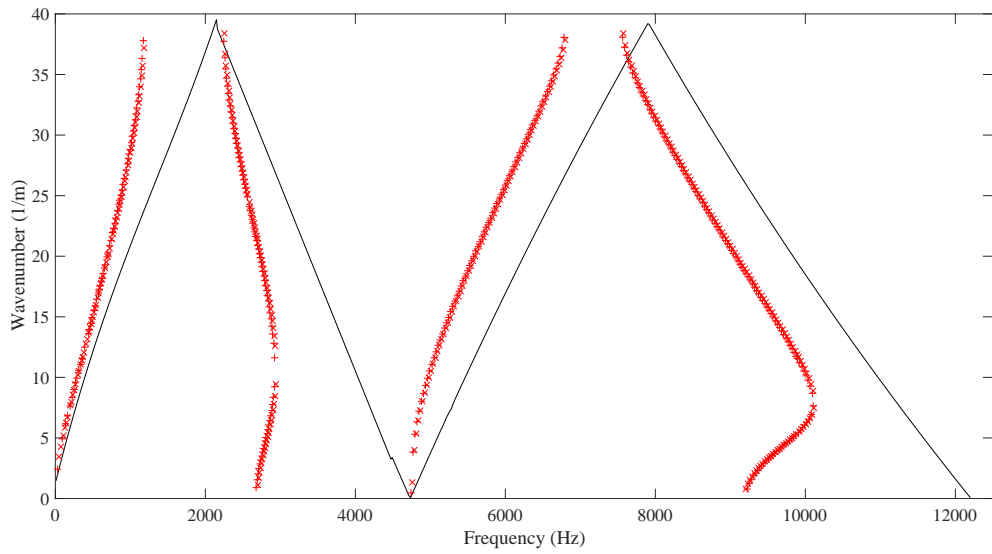

Figure 5: Wavenumber curves of the sandwich beam with: (-) homogenous core, (x) periodically hollow core, (+) periodically hollow core and 10bar pressure applied on the skins

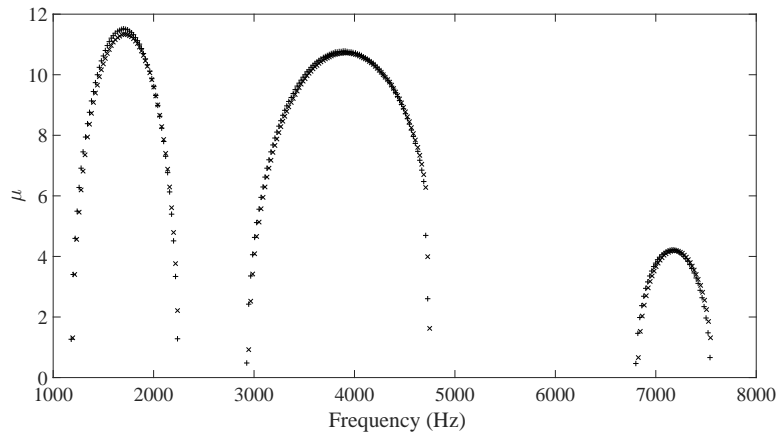

Figure 6: Band gaps of sandwich beam with: (x) periodically hollow core, (+) periodically hollow core and pressure 10bar applied on the skins

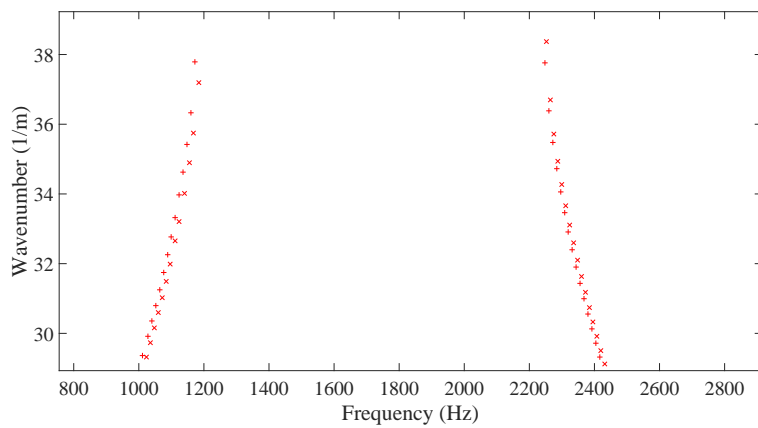

Figure 7: Wavenumber curves of the sandwich beam with: (x) periodically hollow core, (+) periodically hollow core and pressure 10bar applied on the skins

4 Conclusion and Further Work

In this work the banded behaviour of an infinite composite sandwich beam with periodically hollow core was examined, along with the effects of pressure applied in the hollow part of the core. First of all, a suggested method of forming the core of a sandwich beam so that it could induce band gaps in vibration transmission was shown, leading to attenuation of it. In this case, the core was hollow in periodic places of the beam. In addition to this, 10bar pressure was applied on the skins in this hollow part of the beam, so that its effects on the banded behaviour of the beam would be examined. The results of this analysis showed that pressure could be a factor to control the frequency bands of the band gaps, but further analysis is needed. This work can be continued by examining the possibility of controlling the band gap by manipulating the inducing factors: length of the hollow part of the core and pressure magnitude.

References

- [1] G. Floquet, *Sur les équations différentielles linéaires à coefficients périodiques*, Annales Scientifiques de l'École Normale Supérieure, Vol. 12, (1883), pp. 47-88.
- [2] J. W. S. Rayleigh, *On the maintenance of vibrations by forces of double frequency, and on the propagation of waves through a medium endowed with a periodic structure*, Philosophical Magazine, XXIV, (1887), pp. 145-159.
- [3] D. J. Mead, *A general theory of harmonic wave propagation in linear periodic systems with multiple coupling*, Journal of Sound and Vibrations, Vol. 27, No. 2, (1973), pp. 235-260.
- [4] L. Brillouin, *Wave propagation in Periodic Structures*, McGraw-Hill book company, Inc. (1953).
- [5] D. J. Mead, *Wave propagation in continuous periodic structures: research contributions from Southampton, 1964-1995*, Journal of Sound and Vibration, Vol. 190, No. 3, (1996), pp. 45-524.
- [6] M. Ruzzene, F. Scarpa, *Control of wave propagation in sandwich beams with auxetic core*, Journal of Intelligent Material Systems and Structures, Vol. 14, No. 7, (2003), pp. 443-453.
- [7] M. Ruzzene, P. Tsopeles, *Control of wave propagation in sandwich plate rows with periodic honeycomb*, Journal of Engineering Mechanics, Vol. 129, No. 9, (2003), pp. 975-986.
- [8] M. I. Hussein, G. M. Hulbert, R. A. Scott, *Dispersive elastodynamics of 1D banded materials and structures: analysis*, Journal of Sound and Vibration, Vol. 289, No. 4-5, (2006), pp. 779-806.
- [9] M. I. Hussein, G. M. Hulbert, R. A. Scott, *Dispersive elastodynamics of 1D banded materials and structures: design*, Journal of Sound and Vibration, Vol. 307, No. 3-5, (2007), pp. 865-893.
- [10] L. Liu, M. I. Hussein, *Wave motion in periodic flexural beams and characterization of the transition between Bragg scattering and local resonance*, Journal of Applied Mechanics, Vol. 79, No. 1, (2012), pp. 011003-011003-17.
- [11] Z. J. Wu, F. M. Li, Y. Z. Wang, *Vibration band gap behaviors of sandwich panels with corrugated cores*, Computers and Structures, Vol. 129, (2013), pp. 30-39.
- [12] J. S. Chen, C. T. Sun, *Wave propagation in sandwich structures with resonators and periodic cores*, Journal of Sandwich Structures and Materials, Vol. 15, No. 3, (2012), pp. 359-374.
- [13] P. G. Domadiya, E. Manconi, M. Vanali, L. V. Andersen, A. Ricci, *Numerical and experimental investigation of stop-bands in finite and infinite periodic one-dimensional structures*, Journal of Vibration and Control, (2014), pp. 1-12.

- [14] ANSYS and Inc. *ANSYS 14.0 Help file*, (2011).
- [15] B. R. Mace, D. Duhamel, M. J. Brennan, L. Hinke, *Finite element prediction of wave motion in structural waveguides*, Acoustical Society of America , Vol. 117, No. 5, (2005), pp. 2835-2843.
- [16] J. M. Renno, B. R. Mace, *On the forced response of waveguides using the wave and finite element method*, Journal of Sound and Vibration , Vol. 329, No. 26, (2010), pp. 5474-5488.
- [17] L. Hinke, B. R. Mace, M. J. Brennan, *Finite Element Analysis of waveguides*, Institute of Sound and Vibration Research Technical Memorandum, No. 932, (2004).