

Experimental study of a membrane-based dehumidification cooling system

Ziwei Chen¹, Hongyu Bai¹, Zihao Ye¹, Jie Zhu^{1*}

¹*Department of Architecture and Built Environment, University of Nottingham, Nottingham, NG7, 2RD, UK*

Abstract: Membrane-based liquid desiccant dehumidification has attracted increasing interests with elimination of solution droplets carryover problem. A membrane-based hybrid liquid desiccant dehumidification cooling system is developed in this study, which has the ability to remove latent load by a liquid desiccant dehumidification unit and simultaneously to handle sensible load by an evaporative cooling unit. The hybrid system mainly consists of a dehumidifier, a regenerator and an evaporative cooler, calcium chloride is used as liquid desiccant in the system. This paper presents a performance evaluation study of the hybrid system based on experimental data. Series of tests have been conducted to clarify the influences of operating variables and conditions (i.e. desiccant solution concentration ratio, regeneration temperature, inlet air condition, etc.) on the system performance. The experimental results indicate that the system is viable for dehumidification cooling purpose, with which the supply air is provided at temperature of 20.4°C for the inlet air condition at temperature of 34°C and relative humidity of 73%. At desiccant solution concentration ratio of 36%, the thermal COP_{th} of 0.70 and electrical COP_{el} of 2.62 are achieved respectively under steady operating condition.

Keywords: Liquid desiccant dehumidification, Membrane-based, Evaporative cooling

1 Introduction

Desiccant cooling has been regarded as one of the environmental-friendly air conditioning approaches without the shortcomings of overcooling and reheating¹. Compared with the solid desiccant system, the liquid desiccant system is more economical and flexible in utilization of low-grade energy sources² and efficient in providing high quality supply air with independent humidity and temperature controls³. Generally, the selection of a liquid desiccant depends on various operating parameters, such as boiling point elevation, energy storage density, regeneration temperature, thermophysical properties, availability and costs⁴. Halide salts are the most common liquid desiccants, such as Lithium Chloride (LiCl), Lithium Bromide (LiBr) and Calcium Chloride (CaCl₂). Among them, CaCl₂ is the cheapest and most readily available desiccant⁵. There are various packing types of the liquid desiccant system, such as wetted wall, spray tower, packed column and membrane-based⁶. The membrane-based system using an indirect contact for dehumidification has been more attractive with elimination of solution carryover problem. Membrane acting as a selective barrier allows heat and moisture transfer between solution and airstream, and meanwhile prevents the entrainment of liquid desiccant⁷.

Various experimental studies on the membrane-based liquid desiccant dehumidification system have been conducted. Abdel-Salam, et al.⁸ proved the feasibility of a membrane-based desiccant air conditioning system powered by solar

*Corresponding author: Jie Zhu, Email: jie.zhu@nottingham.ac.uk.

energy. El-Dessouky, et al.⁹ proposed a novel air conditioning system integrating a membrane dehumidification unit with an indirect/direct evaporative cooler, and found that 86.2% energy saving can be achieved compared with a stand-alone vapour compression system. Jradi and Riffat¹⁰ developed a hybrid dehumidification cooling system, with which the supply air temperature and humidity reduce from 33.8°C to 22.3°C and 68.6% to 35.5% respectively. Regarding to the membrane-based liquid desiccant dehumidification cooling system, few researches have been carried out for feasibility study and performance evaluation through experimental work. In this study, a membrane-based hybrid dehumidification cooling system is built for experimental investigation. The system feasibility and performance are evaluated under various operation conditions; the influences of inlet air condition, desiccant concentration and regeneration temperature on the system performance are investigated based on the experimental results.

2 Experimental set-up

The hybrid system consists of four main components: a dehumidifier, a regenerator, an evaporative cooler and an air-to-air heat exchanger, as illustrated in Figure 1. Three processes are involved in the system, namely: dehumidification, regeneration and evaporative cooling. The cool airstream from the evaporative cooler is used to cool the dry air to meet the supply requirement in the air-to-air heat exchanger. After dehumidification, the solution is dilute and flows directly to the weak solution storage tank. A magnetic-driven pump delivers the diluted solution from the storage tank to a heat exchanger (HX2), where the weak solution is pre-heated before being heated by hot water. Cold water cools the strong desiccant solution prior to flowing into the dehumidifier and then flows directly into the evaporative cooler. Aqueous CaCl₂ solution is used for experiment.

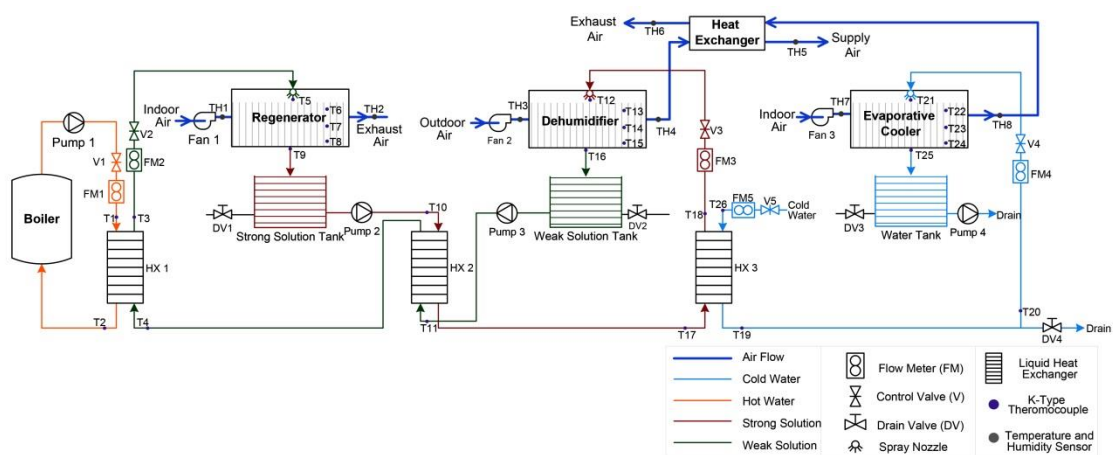

Figure 1 Schematic graph of the membrane-based dehumidification cooling system

Both the dehumidifier and regenerator are membrane-based with the dimension of 410mm (L) x 230mm (W) x 210mm (H), as shown in Figure 2, while for the evaporative cooler with the same dimension, air channels are formed by fibre without membrane sheets, which provides wet surface as cold water flowing downwards.

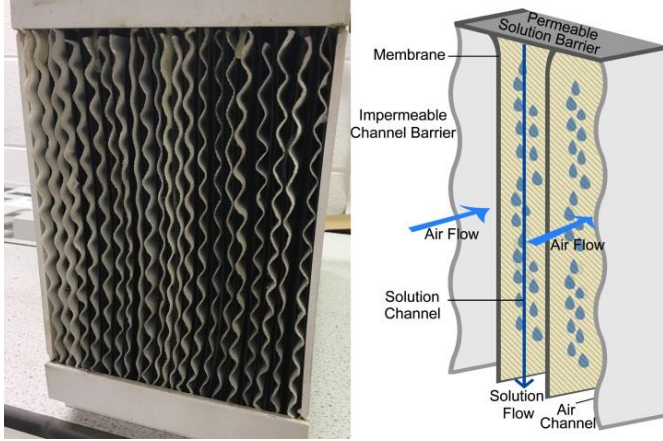

Figure 2 Illustration of the membrane-based unit

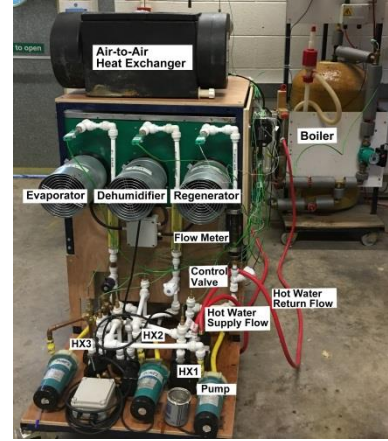

Figure 3 Test rig photo

2.1 Method

The system test rig is shown in Figure 3, insulation is applied for air ducting, pipe work and heat exchangers to reduce the surrounding effects. Main experimental equipment with their specifications is listed in Table 1.

Table 1 Specifications of main equipment

Equipment	Properties	Manufacturer
Magnetic pump	Power	15 W
	Maximum frequency	50 Hz
	Maximum speed	2600 r/min
	Maximum capacity	10 L/min
AC axial fan	Power	45W
	Nominal speed	2800 min ⁻¹
Boiler	Capacity	3kW
	Supply temperature range	50-80°C
	Water storage	120 Litre
	Circulating pump	45W
	Water flow rate	6 L/min

All inlets and outlets are instrumented with humidity and temperature probes and desiccant solution and water flows are instrumented with K-type thermocouples. Air velocities are measured with an anemometer. The main measurement devices and associated accuracies are indicated in Table 2. The solution density is measured with a hydrometer and a correlation determined by Melinder¹¹ is used to calculate CaCl₂ solution concentration ratio based on the solution density and temperature. Desiccant solution/water volumetric flow rates are measured by liquid flow indicators. The float style flow meters are generally calibrated with water at 20°C according to density and dynamical viscosity, so a correction correlation is used to equate the volumetric flow rate reading from the flow meter to the actual desiccant solution flow rate in the dehumidifier/regenerator unit¹².

$$v_{\text{sol}} = v_{\text{w}} \sqrt{\frac{(m_{\text{float}} - V_{\text{float}} \rho_{\text{sol}}) \rho_{\text{w}}}{(m_{\text{float}} - V_{\text{float}} \rho_{\text{w}}) \rho_{\text{sol}}}} \quad (1)$$

where, v_{sol} and v_{w} are volumetric flow rates of the desiccant solution and water respectively, L/min. ρ_{sol} and ρ_{w} are densities of solution and water, kg/m³. For the flow meter, the float weight m_{float} is 2.1×10^{-3} kg and volume V_{float} is 0.25×10^{-6} m³.

Table 2 Measurement devices and associated accuracies

Measurement Devices	Measurement Range	Accuracy
K-type thermocouple probe	Temperature	0-1100°C
Sensirion humidity sensor	Temperature	-40 - +125°C
	Relative humidity	0 - 100%
Parker liquid flow indicator	Liquid flow rate	4-22 L/min
Testo thermo-anemometer	Air velocity	0-10 m/s
Brannan hydrometer 200 Series	Solution density	1.0-1.6 g/m ³
Data logger DT500	Data Acquisition	±0.15%

Uncertainty analysis provides the associated error measure of a calculated value using the given equation. Error bars are included in the graphs for experimental result analysis.

$$U_y = \sqrt{\sum_{i=1}^N \left(\frac{\partial y}{\partial x_i}\right)^2 \cdot U_{x_i}^2} \quad (2)$$

where, U_{x_i} is uncertainty of each measured variable x_i .

2.2 Performance evaluation metrics

Dehumidification process

The dehumidification performance is evaluated by moisture removal rate.

$$M_r = \dot{m}_{\text{air_DH}} \cdot (\omega_{\text{in_DH}} - \omega_{\text{out_DH}}) \quad (3)$$

where, M_r represents moisture removal rate, g/s. $\dot{m}_{\text{air_DH}}$ is mass flow rate of air passing through the dehumidifier, kg/s, $\omega_{\text{in_DH}}$ and $\omega_{\text{out_DH}}$ are air humidity ratios at the inlet and outlet of the dehumidifier, kg/kg_{dryair}. Thermophysical properties of the moist air are determined using equations defined by Tsilingiris¹³.

The dehumidification effectiveness is defined as the ratio of actual change in moisture content to the maximum moisture transfer.

$$\eta_{\text{DH}} = \frac{\omega_{\text{in_DH}} - \omega_{\text{out_DH}}}{\omega_{\text{in_DH}} - \omega_{\text{eq_DH}}} \quad (4)$$

where, η_{DH} is the dehumidification effectiveness. $\omega_{\text{eq_DH}}$ is equilibrium humidity ratio of desiccant solution at the inlet condition, kg/kg_{dryair}. Under the equilibrium state, it is given as¹⁴:

$$\omega_{\text{eq_DH}} = 0.62198 \frac{P_{\text{sol}}}{P_A - P_{\text{sol}}} \quad (5)$$

where, P_A is atmospheric pressure, Pa, and P_{sol} is vapour pressure of CaCl₂ solution at given temperature, Pa, which can be calculated with the empirical correlation derived by Cisternas and Lam¹⁵.

Based on the enthalpy difference of the inlet and outlet air in the dehumidifier, the dehumidifier cooling output is determined as:

$$\dot{Q}_{\text{DH_cooling}} = \dot{m}_{\text{air_DH}} (h_{\text{in_DH}} - h_{\text{out_DH}}) \quad (6)$$

where, $\dot{Q}_{\text{DH_cooling}}$ is the dehumidifier cooling output, W. $h_{\text{in_DH}}$ and $h_{\text{out_DH}}$ are specific enthalpies of inlet air entering the dehumidifier and leaving the dehumidifier, J/kg.

Regeneration process

The regeneration performance is evaluated by moisture addition rate.

$$M_a = \dot{m}_{\text{air_RE}} \cdot (\omega_{\text{out_RE}} - \omega_{\text{in_RE}}) \quad (7)$$

where, M_a represents moisture addition rate, g/s. $\dot{m}_{\text{air_RE}}$ is air mass flow rate passing through the regenerator, kg/s. $\omega_{\text{in_RE}}$ and $\omega_{\text{out_RE}}$ are air humidity ratios at the inlet and outlet of the regenerator, kg/kg_{dryair}.

The thermal input of the regenerator is determined as:

$$\dot{Q}_{\text{RE}} = \dot{m}_{\text{w_RE}} \cdot c_{\text{p_w_RE}} (T_{\text{w_f}} - T_{\text{w_r}}) \quad (8)$$

where, \dot{Q}_{RE} is the regenerator thermal input, W. $\dot{m}_{\text{w_RE}}$ and $c_{\text{p_w_RE}}$ are water mass flow rate, kg/s, and specific heat capacity, J/kg, in the heating circuit. $T_{\text{w_f}}$ and $T_{\text{w_r}}$ are hot water supply and return temperatures respectively, °C.

Coefficient of performance

The total cooling output of the hybrid system is expressed as:

$$\dot{Q}_{\text{cooling}} = \dot{m}_{\text{air_DH}} (h_{\text{in_DH}} - h_{\text{supply}}) \quad (9)$$

where, \dot{Q}_{cooling} is the system total cooling output, W. h_{supply} is specific enthalpy of supply air, J/kg.

The hybrid system overall coefficients of performance (COP) are defined as:

$$\text{COP}_{\text{th}} = \frac{\dot{Q}_{\text{cooling}}}{\dot{Q}_{\text{RE}}} \quad (10)$$

$$\text{COP}_{\text{el}} = \frac{\dot{Q}_{\text{cooling}}}{W_e} \quad (11)$$

where, COP_{th} is thermal coefficient of performance and COP_{el} is electrical coefficient of performance. W_e is electrical consumption, W.

3 Results and Discussion

Table 3 presents the operating variables for the experiment. The effects of operating variables on the dehumidifier and regenerator performances are investigated with CaCl₂ solution concentration ratio of 39%.

Table 3 Operating variables in the experiment

Variables	Range	
<i>Dehumidifier</i>		
Desiccant solution flow rate	0.4 L/min	
Solution concentration ratio	30-42%	
Air volumetric flow rate	35 m ³ /hr	
Inlet air condition	34-35°C	50-75% RH
<i>Regenerator</i>		
Hot water supply temperature	55-80°C	
Hot water supply flow rate	2 L/min	
Desiccant solution flow rate	1 L/min	
Air volumetric flow rate	44-148 m ³ /hr	
Inlet air condition	26°C	33% RH
<i>Evaporative cooler</i>		
Inlet air condition	26°C	33% RH
Cold water supply temperature	10°C	
Cold water supply flow rate	12 L/min	

3.1 Effect of inlet air relative humidity on dehumidification performance

The inlet air temperature for the dehumidifier is set at 34.6°C and relative humidity varies from 46% to 70%. It can be seen from Figure 4(a) that the dehumidifier performance increases with the inlet air relative humidity at the same inlet air temperature. The dehumidifier moisture removal rate doubles as air relative humidity increases from 46% to 70% and the dehumidification effectiveness improves by 36.91%. The increase in the dehumidifier moisture removal rate is caused by the greater vapour pressure difference between the airstream and desiccant solution.

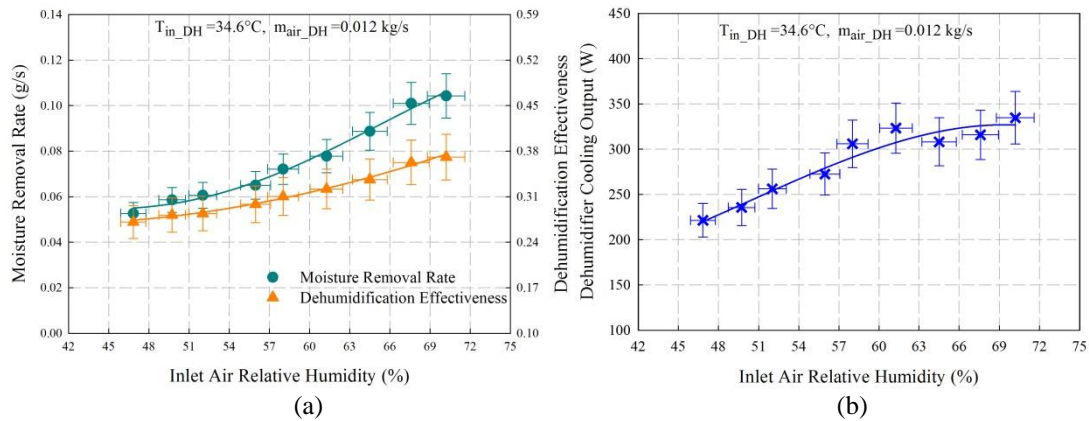

Figure 4 Effects of inlet air relative humidity on (a) moisture removal rate and dehumidification effectiveness and (b) dehumidifier cooling output

Over the investigated inlet air relative humidity range, the higher inlet air relative humidity leads to more cooling output as shown in Figure 4(b). The dehumidifier cooling output increases from 221.37W to 334.67W as air relative humidity increases from 46% to 70%. However, as the relative humidity gets higher than 63%, the increase in the cooling output becomes smaller. It indicates that with further increase in air relative humidity, the dehumidifier cooling output is approaching the maximum capacity.

3.2 Effect of air flow rate on regeneration performance

Tests have been carried out to investigate the air flow rate effect on regeneration performance. At an inlet air condition of 26°C and relative humidity of 33%, the air flow rate of the regenerator is increased from 43.82m³/hr to 148.44m³/hr while the hot water supply is kept at 61°C. As presented in Figure 5(a), there is an increase in the moisture addition rate. Though the increase of air flow rate in the regenerator leads to reduction in the moisture addition capability, the moisture addition rate takes both the moisture content change and the air flow rate into account. The moisture addition rate only increases by 0.04g/s over the investigated air volumetric flow rate range, which indicates that the impact of the air flow rate on regeneration performance is not very significant.

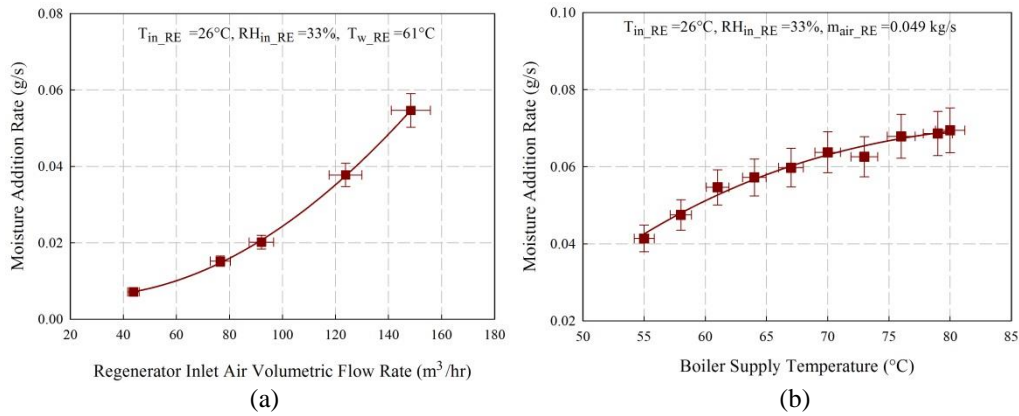

Figure 5 Effects of (a) air flow rate and (b) hot water supply temperature on moisture addition rate

3.3 Effect of hot water supply temperature on regeneration performance

To identify the effect of hot water supply temperature on regeneration performance, the hot water temperature is set in the range from 55°C to 80°C. As presented in Figure 5(b), the regeneration performance improves gradually with the hot water supply temperature. The moisture addition rate increases by 75% as the hot water supply temperature increases from 55°C to 80°C. The increase in the hot water supply temperature results in higher desiccant solution temperature in the regenerator, and thus higher vapour pressure is obtained in solution side. Then the greater vapour pressure difference between the desiccant solution and airstream leads to more mass transfer in the regeneration process at the same inlet air condition. Moreover, as the hot water supply temperature is above 70°C, the increase in the moisture addition rate becomes slow. The variation in the air humidity ratio across the regenerator is only 0.06g/kg_{dryair} as the temperature increases from 70°C to 80°C. Therefore, regarding to the feasibility of integrating renewable energy for thermal input, at the given operating condition, hot water supply temperature up to 70°C is sufficient for adequate regeneration performance.

3.4 Effect of concentration ratio on system performance

According to the operative concentration level of CaCl₂, investigations have been conducted with solution concentration ratio from 30% to 42%. The dehumidification effectiveness increases with solution concentration ratio as shown in Figure 6(a). For desiccant solution concentration ratio below 33%, there is only slight difference in the dehumidifier effectiveness, which implies the operative concentration ratio needs to be at least above 33%. As solution concentration ratio gets higher than 33%, the dehumidifier effectiveness improves more significantly and reaches up to 0.54 for concentration ratio of 42%. For operation of the liquid desiccant system, higher desiccant solution concentration ratio would be better for dehumidification performance. However, the use of highly concentrated solution may cause salt crystallization, which may lead to risks of fluid mal-distribution, channel blockage, high pumping pressure, and membrane fouling. On the other hand, the dehumidifier cooling output also increases from 180.99W to 428.78W with increase of solution concentration ratio, which is related to the higher moisture removal rate in the dehumidifier.

Figure 6(b) shows that the dehumidification performance improves with the desiccant solution concentration ratio under the same inlet condition. As concentration ratio

increases from 30% to 42%, the dehumidifier's moisture removal rate improves from 0.05 g/s to 0.14 g/s while the regenerator moisture addition rate decreases from 0.11 g/s to 0.05 g/s. For the dehumidification process, the driving force caused by the vapour pressure difference between airstream and desiccant solution gets higher for stronger solution, which thus leads to greater moisture removal rate in the dehumidifier. On the contrary, in the regeneration process, the desiccant solution with higher concentration ratio has lower capability for moisture addition due to the lower vapour pressure.

To allow continuous operation of the dehumidifier, the performance of regenerator should match with that of dehumidifier as the mass imbalance issue would result in problems such as the dilution of desiccant solution over time. For the investigated operating condition, the dehumidification and regeneration processes are balanced at desiccant solution concentration ratio of 36%, as the dehumidifier moisture removal rate matches the regenerator moisture addition rate. Thus, measures are needed to facilitate the regenerator performance for the stronger desiccant solution and the dehumidification performance should be improved at lower concentration ratio. Under the system steady operation condition, the thermal COP_{th} and electrical COP_{el} reach up to 0.70 and 2.62 respectively at concentration ratio of 36%, while the supply air temperature is provided at 20.4°C. Hence, the results reveal that the hybrid system is feasible for applications, and the supply air condition could meet the comfortable indoor environment requirement.

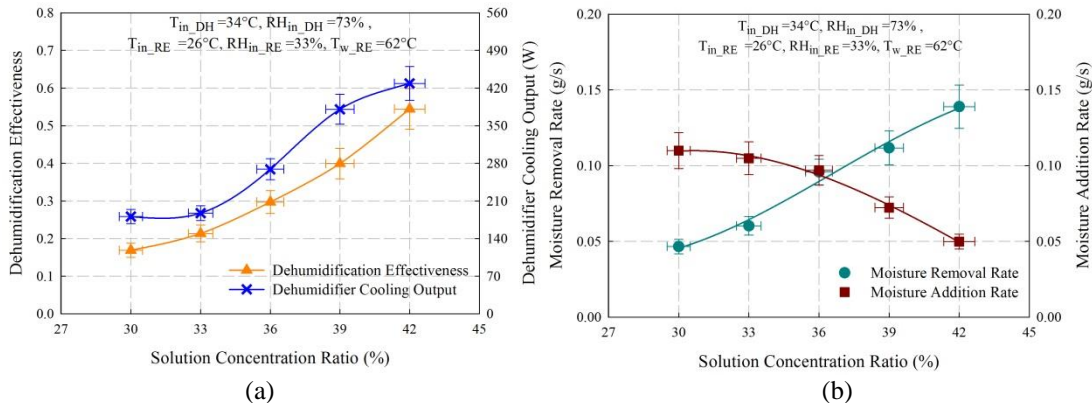

Figure 6 Effects of solution concentration ratio on (a) dehumidification effectiveness and cooling output and (b) moisture removal and addition rates

4 Conclusion

A membrane-based hybrid liquid desiccant dehumidification cooling system has been developed to provide efficient temperature and humidity controls in the hot and humid regions. The experimental results indicate the system with $CaCl_2$ desiccant solution is feasible for dehumidification and cooling purpose under the tested hot and humid condition. Over the investigated variable operating conditions, the system dehumidification performance increases with inlet air relative humidity. On the other hand, the regenerator performance increases with inlet air flow rate and hot water supply temperature. As the hot water supply temperature increases from 55°C to 80°C, the regenerator moisture addition rate increases by 75% under the constant inlet air condition. By increasing the desiccant solution concentration ratio from 30% to 42%, the dehumidification performance improves from 0.05g/s to 0.14g/s and the dehumidifier cooling output doubles. At solution concentration ratio of 36%, the supply air temperature of 20.4°C is achieved for an inlet air condition at temperature

of 34°C and relative humidity of 73%. The thermal COP_{th} achieves up to 0.70 and the electrical COP_{el} reaches to 2.62 with CaCl₂ desiccant solution concentration ratio of 36%.

Acknowledgements

The authors gratefully acknowledge the scholarship support from the Faculty of Engineering of the University of Nottingham.

References

1. Daou, K., Wang, R. & Xia, Z. Desiccant cooling air conditioning: a review. *Renewable and Sustainable Energy Reviews* **10**, 55-77 (2006).
2. Wang, X., Cai, W., Lu, J., Sun, Y. & Ding, X. Heat and Mass Transfer Model for Desiccant Solution Regeneration Process in Liquid Desiccant Dehumidification System. *Industrial & Engineering Chemistry Research* **53**, 2820-2829 (2014).
3. Zhang, L.-Z. Progress on heat and moisture recovery with membranes: From fundamentals to engineering applications. *Energy Conversion and Management* **63**, 173-195 (2012).
4. Ahmed, S.Y., Gandhidasan, P. & Al-Farayedhi, A.A. Thermodynamic analysis of liquid desiccants. *Solar Energy* **62**, 11-18 (1998).
5. Mei, L. & Dai, Y.J. A technical review on use of liquid-desiccant dehumidification for air-conditioning application. *Renewable and Sustainable Energy Reviews* **12**, 662-689 (2008).
6. Qi, R., Lu, L. & Jiang, Y. Investigation on the liquid contact angle and its influence for liquid desiccant dehumidification system. *International Journal of Heat and Mass Transfer* **88**, 210-217 (2015).
7. Huang, S.-M. & Zhang, L.-Z. Researches and trends in membrane-based liquid desiccant air dehumidification. *Renewable and Sustainable Energy Reviews* **28**, 425-440 (2013).
8. Abdel-Salam, A.H., Ge, G. & Simonson, C.J. Thermo-economic performance of a solar membrane liquid desiccant air conditioning system. *Solar Energy* **102**, 56-73 (2014).
9. El-Dessouky, H.T., Ettouney, H.M. & Bouhamra, W. A Novel Air Conditioning System. *Chemical Engineering Research and Design* **78**, 999-1009 (2000).
10. Jradi, M. & Riffat, S. Experimental investigation of a biomass-fuelled micro-scale tri-generation system with an organic Rankine cycle and liquid desiccant cooling unit. *Energy* **71**, 80-93 (2014).
11. Melinder, Å. *Thermophysical Properties of Aqueous Solutions Used as Secondary Working Fluids [Elektronisk resurs]*, (KTH, Stockholm, 2007).
12. Liu, S. University of Nottingham (2008).
13. Tsilingiris, P.T. Thermophysical and transport properties of humid air at temperature range between 0 and 100 °C. *Energy Conversion and Management* **49**, 1098-1110 (2008).
14. ASHRAE. 2013 ASHRAE Handbook - Fundamentals (I-P Edition). (American Society of Heating, Refrigerating and Air-Conditioning Engineers, Inc., 2013).

15. Cisternas, L.A. & Lam, E.J. An analytic correlation for the vapour pressure of aqueous and non-aqueous solutions of single and mixed electrolytes. Part II. Application and extension. *Fluid Phase Equilibria* **62**, 11-27 (1991).

Nomenclature

c_p	Specific heat capacity (J/kg.K)	Greek symbols	
h	Specific enthalpy (J/kg.K)	η_{DH}	Dehumidification effectiveness
\dot{m}	Mass flow rate (kg/s)	ρ	Density (kg/m ³)
m_{float}	Flow meter float weight (kg)	ω	Air humidity ratio (kg/kg _{dryair})
M_a	Moisture addition rate (g/s)	Subscripts	
M_r	Moisture removal rate (g/s)	air	Air
P	Pressure (Pa)	eq	Equilibrium state
$\dot{Q}_{cooling}$	Total cooling output (W)	in	Inlet
$\dot{Q}_{DH_cooling}$	Dehumidifier cooling output (W)	out	Outlet
\dot{Q}_{RE}	Regenerator thermal input (W)	S	Saturation
T	Temperature (°C)	sol	Solution
T_{w_f}	Hot water supply temperature (°C)	w	Water
T_{w_r}	Hot water return temperature (°C)	Abbreviations	
x_i	Measured variable	COP	Coefficient of performance
U_x	Measured variable uncertainty	DH	Dehumidifier
U_y	Variable uncertainty	EV	Evaporative cooler
v	Volumetric flow rate (L/min)	RE	Regenerator
V_{float}	Flow meter float volume (m ³)		
W_e	Total electrical requirement (W)		