

Modulated Model Predictive Control for a 7-Level Cascaded H-Bridge Back-to-Back Converter

Luca Tarisciotti, *Student Member, IEEE*, Pericle Zanchetta, *Member, IEEE*, Alan Watson, *Member, IEEE*, Stefano Bifaretti, *Member, IEEE* and Jon C. Clare, *Senior Member, IEEE*

Abstract— Multilevel Converters are known to have many advantages for electricity network applications. In particular Cascaded H-Bridge Converters are attractive because of their inherent modularity and scalability. Predictive control for power converters is advantageous as a result of its applicability to discrete system and fast response. In this paper a novel control technique, named Modulated Model Predictive Control, is introduced with the aim to increase the performance of Model Predictive Control. The proposed controller address a modulation scheme as part of the minimization process. The proposed control technique is described in detail, validated through simulation and experimental testing and compared with Dead-Beat and traditional Model Predictive Control. The results show the increased performance of the Modulated Model Predictive Control with respect to the classic Finite Control Set Model Predictive Control, in terms of current waveform THD. Moreover the proposed controller allows a multi-objective control, with respect to Dead-Beat Control that does not present this capability.

Index Terms— Multilevel Converters; Predictive Control; Smart Grid.

I. INTRODUCTION

IN the coming years the electricity networks of the world are likely to change as a result of the penetration of renewable energy sources (RES) and other Distributed Generation (DG) sources into their structure. Active networks are considered a viable option which may be applied to facilitate the use of distributed generation systems to produce energy, in particular RES, which are quickly growing as a result of initiatives to reduce carbon emissions. The active networks architecture employs an increased number of power input nodes that can enable the direct routing of electricity. To realize the nodes of the grid, new power electronic systems offer a promising solution to route the electrical energy and provide an interface for DG and renewable energy sources [1].

Multilevel converters have the capability to distribute voltage stress across several series-connected devices, reducing the voltage rating requirement of components, whilst producing high quality AC waveforms even if low device switching frequency is used, reducing filtering requirements. The high overall efficiency identifies multilevel converters as a very promising solution for use in the future electricity grids but more complex circuitry and control are required [2]. Different structures of multi-level converters are proposed in literature [3]. Amongst these, Cascade H-Bridge Converters (CHB) present many benefits including a high level of modularity, as a result of their structure, and availability [3]; in addition, they are widely used in single-phase Photovoltaic inverters [4]–[8] or in neutral-connected three-phase power distribution systems [9]–[11]. In such scenarios, the control of power electronic converters represents one of the key technologies to enable enhanced capabilities, such as reverse power flow, fault ride-through and robustness against grid anomalies whilst maintaining a power quality compliant with international grid codes.

A. Control of power electronics converters

Several control techniques have been studied and applied to three-phase converters in stationary [12] and synchronous [13] reference frames. The control of single-phase structures is also considered in neutral connected three-phase systems in natural, stationary and synchronous reference frames [14]. Moreover model based control techniques are frequently investigated for their fast transient response and harmonic rejection capability [15]–[17]. Dead-Beat Control (DBC) [18]–[20] is a well-known model based control technique providing a fast current tracking and an easy digital implementation. However, a modulator is needed to apply desired output voltage to the converter potentially resulting in a multi-loop control scheme to achieve multi-objective control. On the other hand, Model Predictive Control (MPC) has been widely proposed as a promising solution for the control of power converters [21]–[27], due to its fast dynamic response, easy inclusion of nonlinearities, system constraint and ability to incorporate nested control loops in only one loop and the flexibility to include other system requirements in the controller. MPC may consider a continuous control set [15]; in this case a suitable modulation technique has to be included in the control system. Taking into account the

Manuscript received April 25, 2013; revised July 30, 2013 and October 3, 2013; accepted November 20, 2013.

Copyright © 2013 IEEE. Personal use of this material is permitted. However, permission to use this material for any other purposes must be obtained from the IEEE by sending a request to pubs-permissions@ieee.org.

finite number of output states of a converter, the finite control set MPC [21]–[27] is usually considered because of its robustness and the absence of a modulator. However, the lack of a modulator is also one of the main drawbacks of finite control set MPC and the control can choose only among a limited number of converter output voltages vectors. This generates a larger ripple in the system waveforms which, in turn, requires an increased (and variable) switching frequency in comparison to other control solutions. Several modulation techniques for finite control set MPC are proposed in literature [28]–[35]. In [28]–[30] MPC current control is applied to a six-phase inverter to feed an Asymmetrical Dual Three-Phase Induction Machine while in [31], [32], [35] a Predictive Direct Power Control is applied to a three-phase voltage source converter. Moreover [33], [34] describe a Predictive Direct Torque Control approach. In all those study cases, the duty cycles are calculated by solving an optimization problem. This approach determines the optimal control action in order to track the desired reference with minimal error but, multi-objective control becomes rather complex since it would require a solution for a multidimensional optimization problem to be derived. In order to overcome this limitation, a novel approach, named Modulated Model Predictive Control (M²PC), is presented in this paper. The proposed solution allows retention of all the advantages of MPC as multi-objective control strategy, but produces an increased performance in terms of power quality. M²PC has been tested and evaluated against DBC and the traditional MPC using the the 7-Level CHB shown in Fig. 1. However, the proposed control technique can be also applied to any single phase and three phase converter topologies, by adapting it to the specific case.

B. Converter Description

The structure of a single-phase back-to-back conversion system, based on a cascaded architecture which encompasses all the aforementioned capabilities, is illustrated in Fig. 1. A series input filter L is included to enable power factor control at the grid and provide an acceptable attenuation of the current harmonics. Each bidirectional AC/DC/AC cell is composed of two H-bridges and a medium frequency isolated DC/DC converter as shown in Fig. 1. The converter is connected to the grid on side 1 and an RL load on side 2. The configuration is chosen in order to prove the control capability in different operating modes, with side 1 and side 2 utilizing independent control. In the proposed case study side 1 operates as an Active Rectifier while side 2 operates as inverter. However, the proposed control is also applicable to other converter topologies regardless of their function (e.g. Active Rectifiers, grid-connected systems and, Solid State Transformers [11], [36]). While the control of the DC/DC converter has an independent dynamic with the goal of achieving the same voltage on both side of the converter (or scaled by the transformer turns ratio), the control of the AC/DC bidirectional converter is one of the key elements required to achieve an interconnection of DG into medium voltage networks. In this paper DBC, MPC and the proposed M²PC are implemented and tested in order to compare their performance.

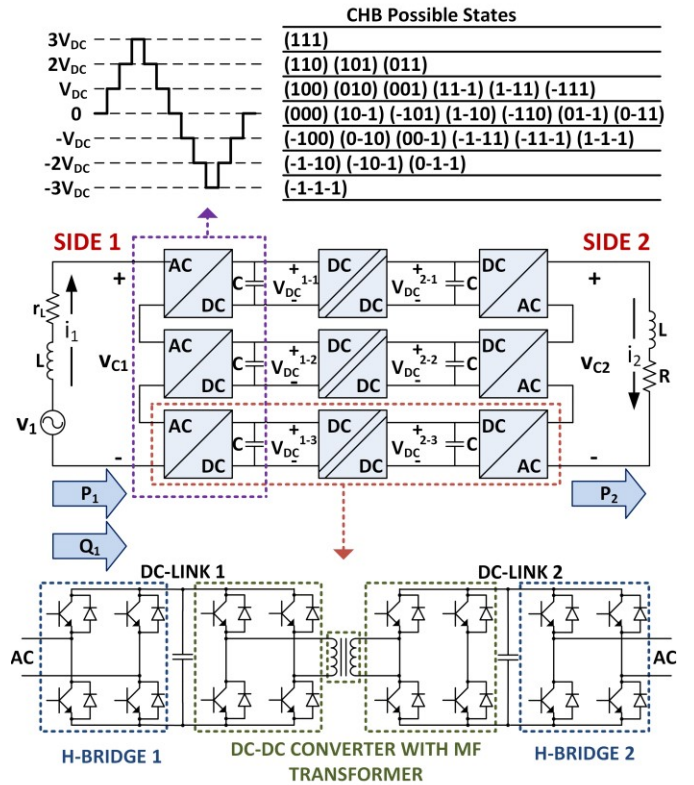

Fig. 1. Converter schematic (center) with detailed schematic of the single cell (bottom) and description of the switching patterns (top).

II. DEAD-BEAT AND PREDICTIVE CONTROL

In order to obtain a fair evaluation of the proposed control technique, the M²PC controller has been compared with two well-known model based control techniques, MPC and DBC controllers which are described in details in the paragraphs below.

A. Dead-Beat Control

Dead-Beat control [18]–[20] is based on the prediction of the system response to a change in control variables in order to achieve (ideally) zero error in the next one, two or more sampling periods. The output of this control is an average value (i.e. continuous) and it is chosen by imposing the current value at the next sampling period equal to the desired reference. A modulator is needed to apply desired output voltage to the converter. Applying this control method, the current will follow the desired reference with zero error at the next sampling period. Looking at side 1 of the converter, the control law can be derived starting from the AC model shown in (1).

$$v_1(t) - v_{c1}(t) = L \frac{di_1(t)}{dt} - r_L i_1(t) \quad (1)$$

Where r_L is the winding resistance of the inductance L . In order to allow the implementation using a DSP, the model in (1) is discretized considering the generic sampling instant $t_k + T_s$, where T_s is the sampling period. In real control systems if the computational time, usually fixed at one sampling interval, is not taken into account, the control action would be performed with a delay of one sampling interval. To compensate for the

mentioned delay, the two sample step prediction proposed in [19] is used, obtaining the following discrete model:

$$v_1(t_k + T_s) - v_{c1}(t_k + T_s) = L \frac{i_1(t_k + 2T_s) - i_1(t_k)}{2T_s} - r_L i_1(t_k + T_s) \quad (2)$$

Imposing the current i_1 at the next sampling interval equal to the reference i_1^* , the control law is obtained as:

$$v_{c1}^*(t_k + T_s) = v_1(t_k + T_s) - \frac{L}{2T_s} [i_1^*(t_k + 2T_s) - i_1(t_k)] + r_L i_1^*(t_k + T_s) \quad (3)$$

Similarly for side 2 of the converter the following control law is obtained:

$$v_{c2}(t) = L \frac{di_2(t)}{dt} + Ri_2(t) \quad (4)$$

$$v_{c2}(t_k + T_s) = L \frac{i_2(t_k + 2T_s) - i_2(t_k)}{2T_s} + Ri_2 \quad (5)$$

$$v_{c2}^*(t_k + T_s) = \frac{L}{2T_s} [i_2^*(t_k + 2T_s) - i_2(t_k)] + Ri_2^*(t_k + T_s) \quad (6)$$

The overall control scheme for the converter is shown in Fig. 2. The aim of the method is to control the AC current in order to regulate the DC link voltages at the required reference and obtain the desired current on side 2 of the converter. The AC current reference is calculated on the basis of the active power reference P^* and the reactive power reference Q^* .

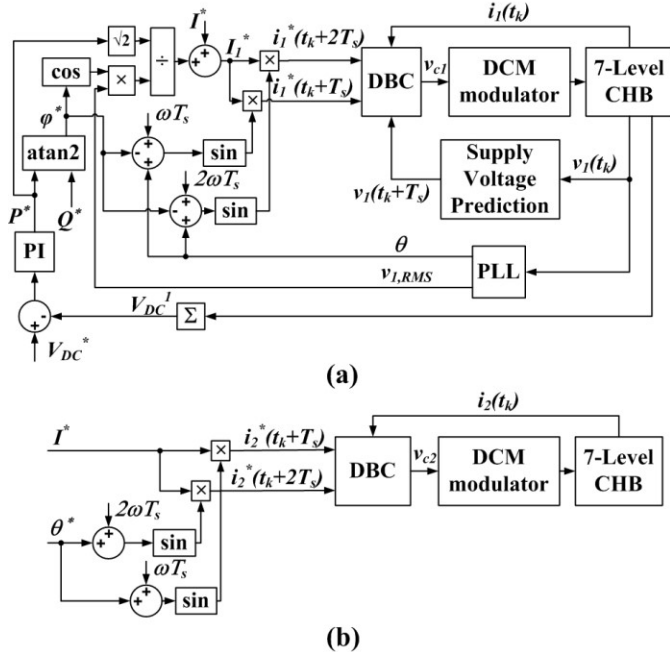

Fig. 2. Dead-Beat Control block schemes: (a) side 1 and (b) side 2 of the AC/DC/AC converter.

The angle and RMS value of the AC voltage, respectively θ and $V_{L,RMS}$, are also needed to synchronize the current reference with the AC voltage supply and are obtained from a PLL [37]–[39]. A Proportional Integral (PI) controller is required to regulate the total DC-Link voltage V_{DC}^l at the desired reference

V_{DC}^* . The Distributed Commutations Modulation (DCM) [40] technique with active DC-Link voltage balancing [41] is used to decrease the switching frequency of every single H-Bridge and, as a consequence, reduce the losses of the converter. The modulation technique allows the converter to switch only one leg of one H-Bridge at every sampling period, obtaining a total switching frequency of the CHB that is the half of the sampling frequency and an individual H-Bridge switching frequency of approximately one third of the total switching frequency for the considered 7-level converter. One issue with this modulation technique is that, because only adjacent vectors can be applied during one sampling interval, the transient response is slower with respect to a modulation scheme without this limitation. However, DCM is particularly suitable for high-power systems where the switching frequency is a critical factor and has to be minimized in order to reduce losses. The Dead-Beat control also requires the prediction of the supply voltage v_l from the previous period, as described in [42].

B. Model Predictive Control

Model Predictive Control [21]–[27] is based, like the Dead-Beat Control, on the prediction of the system response to a change in control variables in order to achieve a minimum error in the next one, two or more sampling periods. The output of this control is a discrete value that can be directly applied to control the converter and is chosen by minimizing a cost function that represents the error between the current and the desired reference. Applying MPC to control the AC current, the desired reference is tracked with minimum error at the next sampling period. Because the control directly applies one switching state for the whole sampling interval, it is necessary to acquire the measurements in the center of the sampling period in order to obtain the average supply current. This introduces a delay of $0.5T_s$ which must be compensated in the control. Starting from eq. (1), the model is discretized around the sampling instants $t_k + 0.5T_s$ and $t_k + 1.5T_s$ obtaining, for side 1 of the converter the following expressions:

$$i_1(t_k + 1.5T_s) = \left(1 - \frac{T_s r_L}{L}\right) i_1(t_k + 0.5T_s) + \frac{T_s}{L} [v_1(t_k + 0.5T_s) - v_{c1}(t_k + 0.5T_s)] \quad (7)$$

$$i_1(t_k + 2.5T_s) = \left(1 - \frac{T_s r_L}{L}\right) i_1(t_k + 1.5T_s) + \frac{T_s}{L} [v_1(t_k + 1.5T_s) - v_{c1}(t_k + 1.5T_s)] \quad (8)$$

The control action is calculated at the instant t_k as if being at the instant $t_k + 0.5T_s$, where $v_{c1}(t_k + 0.5T_s)$ is the value of the converter voltage applied at the previous control step, considering that $v_{c1}(t_k + 0.5T_s) = v_{c1}(t_k)$. The goal is to choose between the possible voltage states which can be generated by the 7-level AC/DC converter, in order to minimize the following cost function

$$G = |i_1(t_k + 2.5T_s) - i_1^*(t_k + 2.5T_s)| \quad (9)$$

Similarly for side 2 of the converter the following control law is obtained.

$$i_2(t_k + 1.5T_s) = \left(1 - \frac{T_s R}{L}\right) i_2(t_k + 0.5T_s) + \frac{T_s}{L} v_{c2}(t_k + 0.5T_s) \quad (10)$$

$$i_2(t_k + 2.5T_s) = \left(1 - \frac{T_s R}{L}\right) i_2(t_k + 1.5T_s) + \frac{T_s}{L} v_{c2}(t_k + 1.5T_s) \quad (11)$$

$$G = |i_2(t_k + 2.5T_s) - i_2^*(t_k + 2.5T_s)| \quad (12)$$

The overall control scheme for the converter is shown in Fig. 3 where the absence of a modulation scheme can be observed. The commutations are distributed amongst the H-Bridges in order to balance the capacitor voltages and only one leg of one H-Bridge is allowed to switch at every sampling period, obtaining a total switching frequency for the CHB that is the half of the sampling frequency. Clearly, as described for DCM modulator in DBC, such a solution represents a limitation in the control capability during transients. However, in high power applications where reduction of switching losses is particularly important, such solution has been considered as the best trade-off between control performance and system requirements. Moreover, in MPC, the proposed switching pattern reduces the computational effort which is an important feature in predictive control design. The aim of the method is to control the AC current in order to regulate the DC link voltages at the required reference and obtain the desired current on side 2 of the converter. The AC current reference is calculated as described for Dead-Beat Control and the prediction of the supply voltage v_1 from previous supply periods as described in [42].

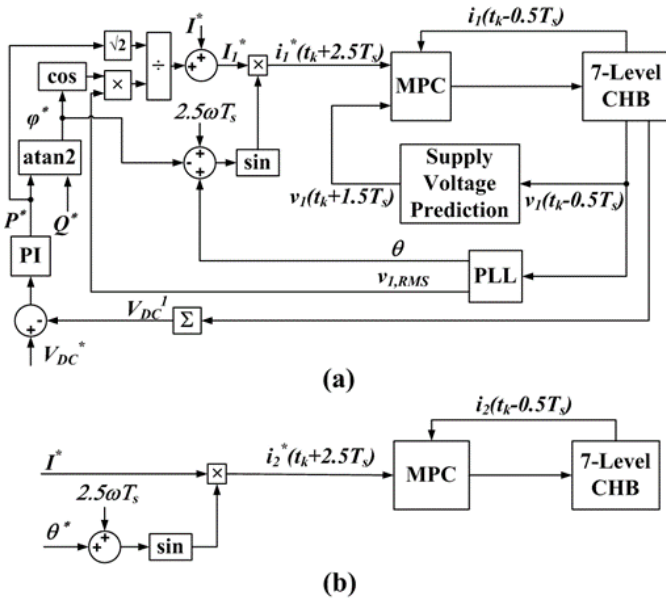

Fig. 3. Model Predictive Control block scheme for side 1 (a) and side 2 (b) of the AC/DC/AC converter.

III. MODULATED MODEL PREDICTIVE CONTROL

Modulated Model Predictive Control (M²PC) includes a suitable modulation scheme in the cost function minimization of the MPC algorithm. To avoid increasing the complexity of

the controller [35], [43], especially in the case of multi-objective cost functions, M²PC is based on the evaluation of the cost function for a selected number of states. In this paper a modulation scheme particularly suitable for high power converters, and similar to the one used in DBC control is reproduced, maintaining the previously described limitations and advantages. Also in this case, at every sampling period, only one leg of one H-Bridge is allowed to switch obtaining a total switching frequency of the CHB that is the half of the sampling frequency. Moreover, as for MPC, the selected switching pattern helps to reduce the controller computational requirements. However, in the case of M²PC the switching times are calculated on the basis of the cost function values for the selected states, as described below.

A. States selection

Considering side 1 of the converter, at every sampling instant, two vectors are selected. The first vector $v_{c1}^{(1)}$ applied to the converter is the same one applied at the end of the previous sampling interval:

$$v_{c1}^{(1)}(t_k + T_s) = v_{c1}^{(2)}(t_k) \quad (13)$$

For this vector the current prediction at the next sampling instant and the relative cost function are calculated as follows:

$$i_1^{(1)}(t_k + 2T_s) = i_1(t_k) - \frac{2T_s r_L}{L} i_1(t_k) + \frac{2T_s}{L} [v_1(t_k + T_s) - v_{c1}^{(1)}(t_k + T_s)] \quad (14)$$

$$G^{(1)} = |i_1^{(1)}(t_k + 2T_s) - i_1^*(t_k + 2T_s)| \quad (15)$$

The second vector $v_{c1}^{(2)}$ is chosen between the two vectors adjacent to $v_{c1}^{(1)}$, on the basis of the current predictions, selecting the vector that minimize the cost function value:

$$i_1^{(2)}(t_k + 2T_s) = i_1(t_k) - \frac{2T_s r_L}{L} i_1(t_k) + \frac{2T_s}{L} [v_1(t_k + T_s) - v_{c1}^{(2)}(t_k + T_s)] \quad (16)$$

$$G^{(2)} = |i_1^{(2)}(t_k + 2T_s) - i_1^*(t_k + 2T_s)| \quad (17)$$

The selection of the second vector has two major advantages: it reduces the complexity of the controller and reduces the device switching frequency. In fact, the next H-Bridge to switch is selected on the basis of the principles of the DCM modulator [40], [41], making the control suitable for high power applications. Similarly, for side 2 of the converter, two vectors are selected. The first vector $v_{c2}^{(1)}$ is the last one applied at the previous sampling interval.

$$v_{c2}^{(1)}(t_k + T_s) = v_{c2}^{(2)}(t_k) \quad (18)$$

While the cost function for $v_{c2}^{(1)}$ is calculated as follows:

$$i_2^{(1)}(t_k + 2T_s) = i_2(t_k) + \frac{2T_s R}{L} i_2(t_k) + \frac{2T_s}{L} v_{c2}^{(1)}(t_k + T_s) \quad (19)$$

$$G^{(1)} = |i_2^{(1)}(t_k + 2T_s) - i_2^*(t_k + 2T_s)| \quad (20)$$

The second vector $v_{c2}^{(2)}$ is chosen between the two vectors adjacent to $v_{c2}^{(1)}$ selecting the vector that minimizes the cost

function value:

$$i_2^{(2)}(t_k + 2T_s) = i_2(t_k) + \frac{2T_s R}{L} i_2(t_k) + \frac{2T_s}{L} v_{c2}^{(2)}(t_k + T_s) \quad (21)$$

$$G^{(2)} = |i_2^{(2)}(t_k + 2T_s) - i_2^*(t_k + 2T_s)| \quad (22)$$

B. State duty calculations

For both sides of the converter, the switching times for the two vectors are calculated by solving the following linear system of equations:

$$\begin{cases} t^{(1)} = \frac{K}{G^{(1)}} \\ t^{(2)} = \frac{K}{G^{(2)}} \\ t^{(1)} + t^{(2)} = T_s \end{cases} \quad (23)$$

Once the value of K is obtained from (23), the following expressions for switching times are obtained:

$$t^{(1)} = T_s \frac{G^{(2)}}{G^{(1)} + G^{(2)}} \quad (24)$$

$$t^{(2)} = T_s \frac{G^{(1)}}{G^{(1)} + G^{(2)}} \quad (25)$$

The time calculation of equations (24) and (25) is a sub-optimal solution based on empirical considerations of the current error related to the control. In fact in this case it is not possible to calculate the optimal value of $t^{(1)}$ and $t^{(2)}$ that minimize the cost function as done in previous work [28]–[35]. However it is possible to demonstrate that the current error for MPC is higher when compared to M²PC. In MPC the current error in one sampling interval is equal to

$$G_{MPC} = G^{(1)} \quad (26)$$

while in M²PC the current error can be approximated as in the following, considering $T_s \ll l$.

$$G_{M2PC} \cong \frac{t^{(1)}G^{(1)} + t^{(2)}G^{(2)}}{2T_s} = \frac{G^{(1)}G^{(2)}}{G^{(1)} + G^{(2)}} < G^{(1)} \quad (27)$$

The last expression in (27) is obtained substituting (24) and (25) in (27). It can be stated that

$$G_{M2PC} < G_{MPC} \quad (28)$$

and the current error in M²PC is reduced with respect to MPC.

C. Overall control scheme

The overall control scheme for the converter is shown in Fig. 4 where the modulation scheme is integrated into the controller as described above. The commutations are distributed amongst the three H-Bridge of each phase in order to balance the capacitor voltages and only one leg of one H-Bridge is allowed to switch at every sampling period, obtaining a total switching frequency for the CHB that is the half of the sampling frequency. The aim of the method is to control the AC current in order to regulate the DC link voltages at the required reference and obtain the desired current on side 2 of the converter. The AC current reference is calculated as described for DBC and MPC using a PLL. A prediction of the supply voltage is also required.

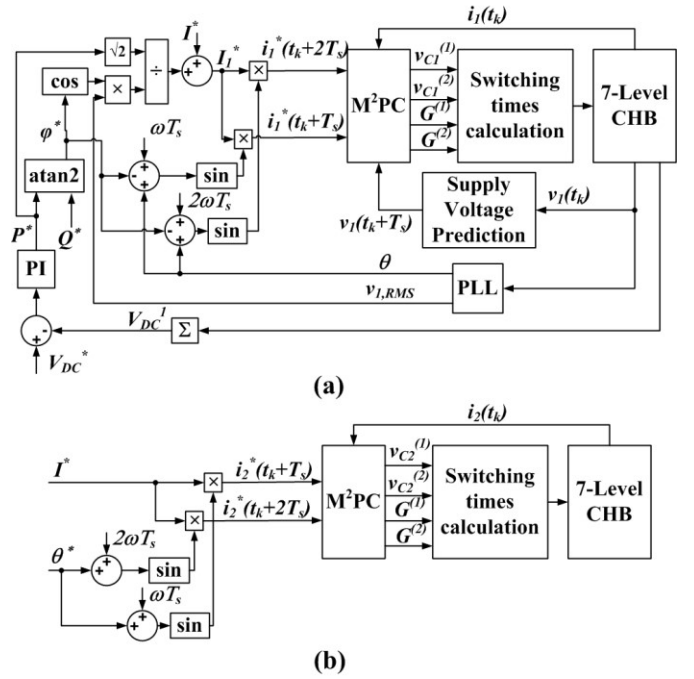

Fig. 4. Modulated Model Predictive Control block scheme for side 1 (a) and side 2 (b) of the AC/DC/AC converter.

IV. SIMULATION RESULTS

To validate the effectiveness of M²PC control, different simulations of the overall system are carried out in comparison with the results obtained with DBC and MPC control. The simulation parameters are shown in Table I.

TABLE I.
SIMULATION AND EXPERIMENTAL PARAMETERS

Symbol	Description	Value	Unit
L	Filter and Load inductance	11	[mH]
r_L	Winding resistance	0.5	[Ω]
R	Load resistance	30	[Ω]
C	Capacitance	3300	[μ F]
T_s	Sampling Period	0.2	[ms]

Fig. 5 shows the behavior of the three controllers on the grid-connected side of the converter when a current step from 4A to 7A is applied on the inverter side, while Fig. 6 shows the response of DBC, MPC and M²PC on the inverter side. The relatively slow response on the grid side to a current step on the inverter side is due to the presence of the PI controller, used to regulate the DC-Link voltages. The DBC controller tracks the reference with zero error while the MPC controller offers non-zero current tracking, especially at low current. Moreover, the MPC controller has a variable switching frequency lower than the half of the sampling frequency. The M²PC controller shows a current tracking and a converter voltage of similar quality to the DBC and the switching frequency is kept constant at half of the sampling frequency. The main advantage is that, because of its nature, M²PC has a major flexibility and is still possible to obtain a multi-objective control using this technique. Fig. 7

shows a zoom of the currents in Fig. 6 to better appreciate the current transient performance. The transient of M²PC presents similar performance to DBC. MPC presents a lower overshoot but, as mentioned earlier, has a higher harmonic content.

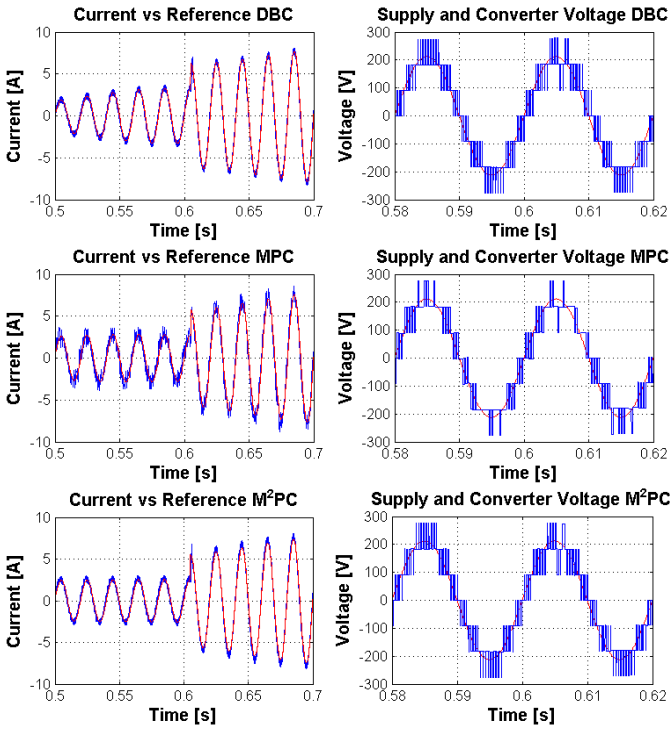

Fig. 5. DBC, MPC and M²PC performance on the grid-connected side when a current step from 4A to 7A is applied on the inverter side.

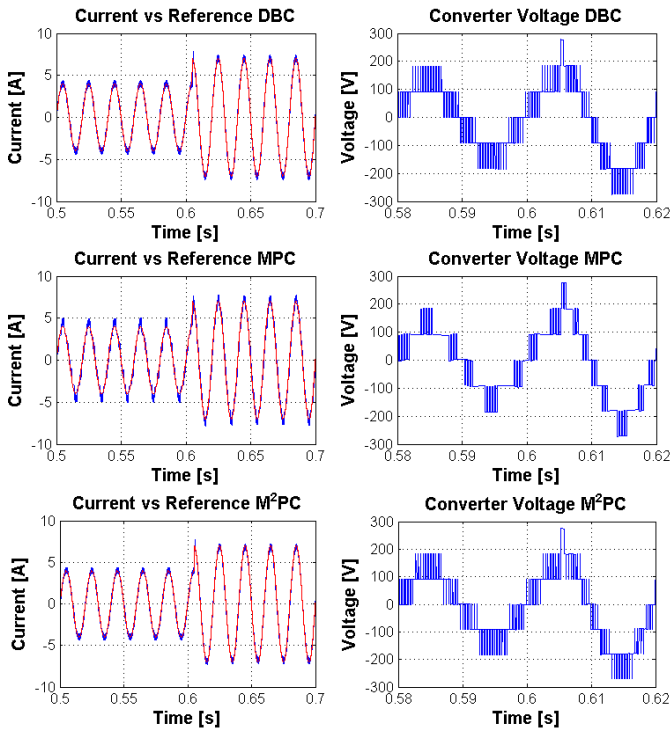

Fig. 6. DBC, MPC and M²PC performance on the inverter side when a current step from 4A to 7A is applied on the inverter side.

Fig. 8 shows the behavior of the three controllers on the grid-connected side of the converter when a positive reactive power

step, according to the power directions of Fig. 1, from 0 VAR to 200 VAR is applied at time instant 1.1s on the grid side. The DBC controller tracks the reference with zero error, but the step response is relatively slow compared to MPC and M²PC controllers that show a faster response. However, only M²PC maintains a superior current quality compared to MPC. Looking at the transient responses in the figures, M²PC generates a slightly larger oscillation on the converter voltage with respect to DBC and MPC. However, M²PC provides a faster current tracking than DBC with dynamic performances comparable with MPC.

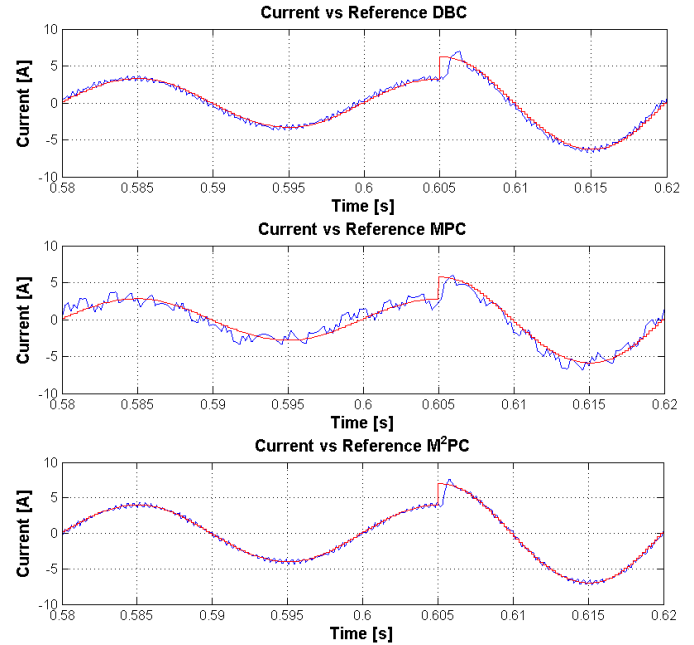

Fig. 7. DBC, MPC and M²PC AC current zoom on the inverter side when a current step from 4A to 7A is applied on the inverter side.

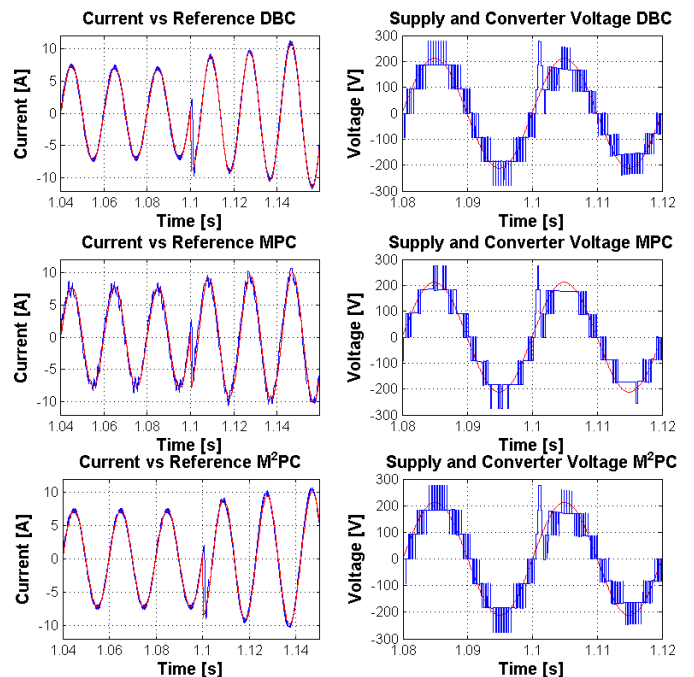

Fig. 8. DBC, MPC and M²PC performance on the grid-connected side when a reactive power step from 0 VAR to 200 VAR is applied on the grid side.

V. EXPERIMENTAL RESULTS

The proposed M^2PC controller is experimentally validated in comparison with DBC and MPC controllers on the UNIFLEX-PM prototype [10], [11], shown in Fig. 9, and composed of 12 fundamental cells each comprising 4 H-bridges and a medium frequency transformer. In the experimental tests of this paper, only the three highlighted cells in Fig. 9 are used to implement the configuration shown in Fig. 1. The control scheme for the converter is implemented on a Texas Instruments 6713 DSP interfaced to five custom FPGA boards. Control of the DC/DC isolation modules, comprising two H-bridges and the MF transformer, is implemented entirely using the FPGA with the aim to equalize the DC-link voltages on the two sides of the converter [44]. Tests are performed using the same parameters shown in Table 1, and a supply voltage of 190V rms. Fig. 10 shows the converter voltages and currents for the three controllers on the grid-connected side of the AC/DC/AC converter. Fig. 11 also shows the converter voltages and currents for the three controllers on the inverter side of the back-to-back converter.



Fig. 9. UNIFLEX-PM power converter in place for low voltage testing: (a) complete 12-cell setup for 3-phase 3-port operation, (b) highlighted cells used for single-phase 2-port operation.

In Figs. 10 and 11, it is possible to observe the similar performances of DBC and M^2PC and that a constant switching frequency of 2.5kHz is maintained. MPC produces a reduced switching frequency of around 1.5kHz. This effect, in addition to the absence of PWM technique, produces poorer performance for MPC compared to DBC and M^2PC , in terms of current THD, as shown in Fig. 12. In fact, looking at the current harmonic content, DBC and M^2PC have a similar spectrum where the harmonics of higher amplitude are located around the switching frequency, resulting in a THD around 2.5% for DBC on both sides of the converter. M^2PC produces a higher THD of 3.1% on the grid-connected side because the reference value for the DC-Link voltages is used instead of the measured value to simplify the cost function minimization. In fact if, the measured DC-Link voltages were to be used, the cost function of M^2PC would have to be evaluated not only for any applicable voltage level, but for any single H-Bridge cell, increasing the

computational effort. The use of the measured DC-Link voltages in the cost function may result in achieving the same performance as DBC: however, the demonstration of such a feature needs further investigation. On the other hand, MPC harmonics are spread across the frequencies below 2.5kHz; in addition, the absence of a modulator, produces an increased THD, equal to 9% on side 1 and to 7% on side 2.

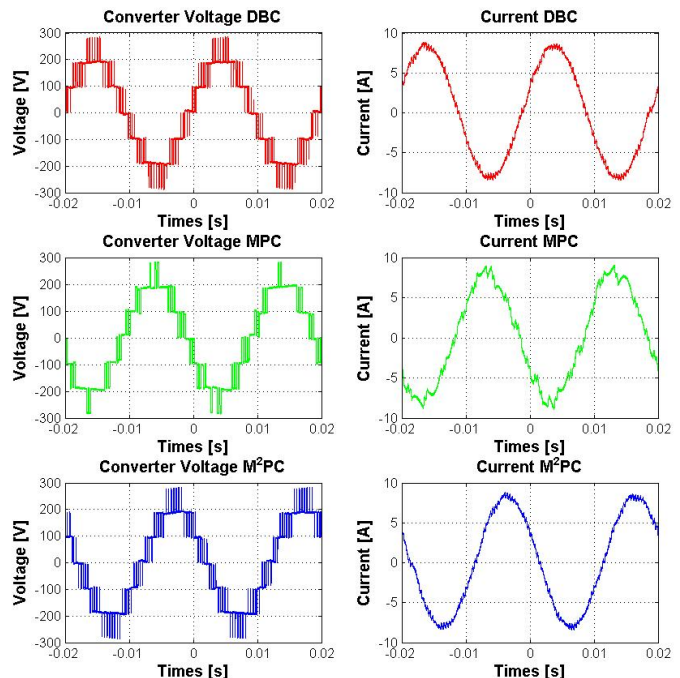

Fig. 10. DBC, MPC and M^2PC controllers steady state operation on the grid-connected side of the converter.

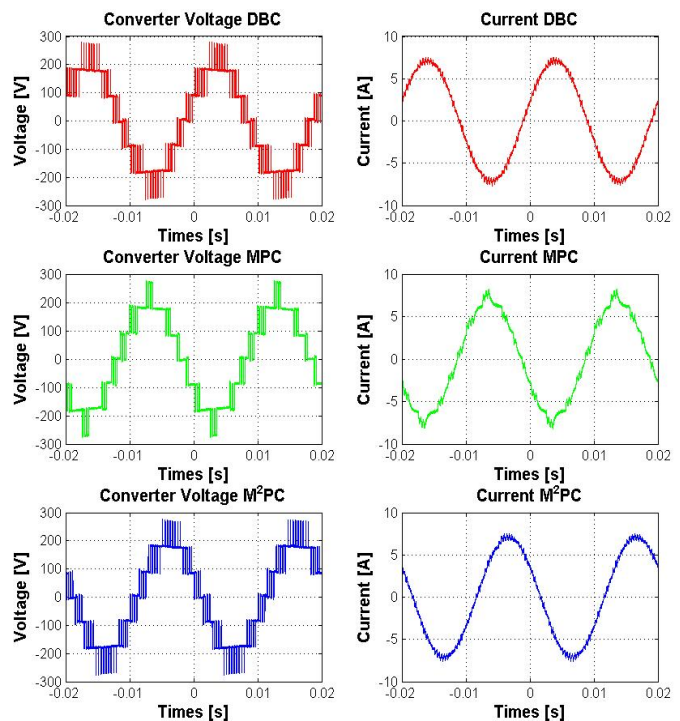

Fig. 11. DBC, MPC and M^2PC steady state operation on the inverter side of the converter.

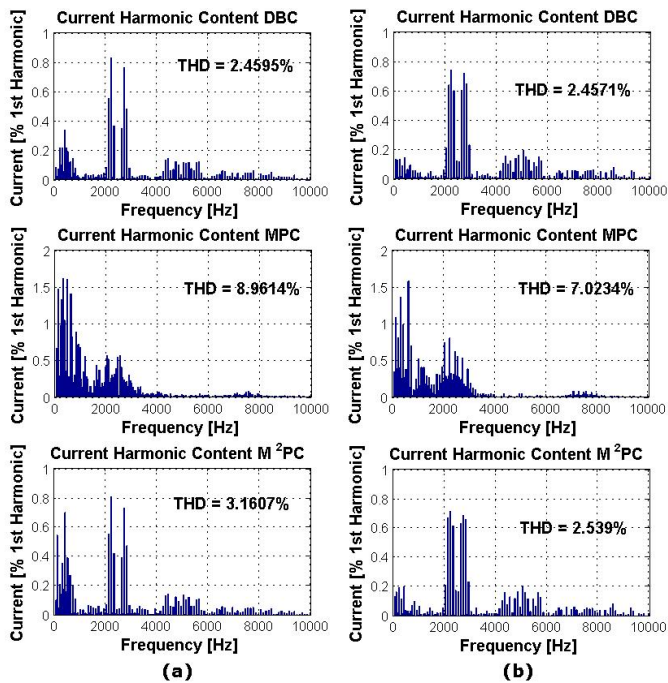

Fig. 12. DBC, MPC and M^2PC controllers current harmonic content: (a) Side 1 (b) Side 2.

VI. CONCLUSIONS

In this paper, a novel model based control technique named M^2PC is presented and applied to a 7-Level CHB back-to-back converter; the proposed control is compared and contrasted to two well-known model based control techniques, respectively Dead-Beat and Model Predictive control. DBC is based on an optimal discrete time control law and requires an external modulator. However a multi-objective control approach is not possible given the nature of the technique. On the other hand MPC is based on an online cost function minimization and, according to the target parameters included, it is possible to achieve a multi-objective control. However, considering a finite control set, MPC applies only one voltage vector in each sampling interval, resulting in a variable switching frequency lower than the sampling frequency. M^2PC combines the main advantage of a MPC control, i.e. the ability to obtain a multi-objective control, and the good performance of a DBC maintaining a switching frequency which is constant and equal to half of the sampling frequency. In fact M^2PC includes, in the minimization algorithm, a PWM technique based on the value of the cost function for different states of the converter. The switching times are calculated using an empirical solution based on the value of the cost functions for two adjacent states providing a sub-optimal solution to the minimization problem. The proposed technique is validated through simulation and experimental testing in comparison with DBC and MPC. The obtained results show a similar behavior for DBC and M^2PC controllers with a fast dynamic and a low current THD for a 2.5 kHz composite switching frequency, while MPC produces the worst performances compared with the other two techniques. In conclusion, M^2PC produces similar performances to DBC and introduces the ability to perform a multi-objective control; for

example, by including the DC-Link voltage control in the cost function, it is possible to obtain a current and DC-Link voltage control without compromising the overall performance of the system. This latter capability will be the subject of future research.

REFERENCES

- [1] P. R. Khatri, V. S. Jape, N. M. Lokhande, and B. S. Motling, "Improving power quality by distributed generation," *Power Engineering Conference, 2005. IPEC 2005. The 7th International*, vol. 2, pp. 675–678, 2005.
- [2] J. S. Lai and F. Z. Peng, "Multilevel converters—a new breed of power converters," *IEEE Trans. Ind. Appl.*, vol. 32, no. 3, pp. 509–517, 1996.
- [3] M. Malinowski, K. Gopakumar, J. Rodriguez, and M. A. Pérez, "A survey on cascaded multilevel inverters," *IEEE Trans. Ind. Electron.*, vol. 57, no. 7, pp. 2197–2206, 2010.
- [4] S. B. Kjaer, J. K. Pedersen, and F. Blaabjerg, "A review of single-phase grid-connected inverters for photovoltaic modules," *IEEE Trans. Ind. Appl.*, vol. 41, no. 5, pp. 1292–1306, Sep. 2005.
- [5] G. Buticchi, E. Lorenzani, and G. Franceschini, "A Five-Level Single-Phase Grid-Connected Converter for Renewable Distributed Systems," *IEEE Trans. Ind. Electron.*, vol. 60, no. 3, pp. 906–918, 2012.
- [6] J. Chavarria, D. Biel, F. Guinjoan, C. Meza, and J. J. Negroni, "Energy-Balance Control of PV Cascaded Multilevel Grid-Connected Inverters Under Level-Shifted and Phase-Shifted PWMs," *IEEE Trans. Ind. Electron.*, vol. 60, no. 1, pp. 98–111, 2013.
- [7] B. Indu Rani, G. Saravana Ilango, and C. Nagamani, "Control Strategy for Power Flow Management in a PV System Supplying DC Loads," *IEEE Trans. Ind. Electron.*, vol. 60, no. 8, pp. 3185–3194, Aug. 2013.
- [8] N. A. Rahim, K. Chaniago, and J. Selvaraj, "Single-phase seven-level grid-connected inverter for photovoltaic system," *IEEE Trans. Ind. Electron.*, vol. 58, no. 6, pp. 2435–2443, 2011.
- [9] S. Bifaretti and P. Zanchetta, "Advanced power electronic conversion and control system for universal and flexible power management," *IEEE Trans. Smart Grid*, vol. 2, no. 2, pp. 231–243, 2011.
- [10] A. Watson, G. Mondal, and H. Dang, "Construction and Testing of the 3.3 kV, 300 kVA UNIFLEX-PM Prototype," *EPE Journal: European Power Electronics and Drives*, vol. 19, no. December, pp. 59–64, 2009.
- [11] F. Iov, F. Blaabjerg, J. Clare, and P. Wheeler, "UNIFLEX-PM-A key-enabling technology for future European electricity networks," *EPE Journal: European Power Electronics and Drives*, vol. 19, no. December, pp. 6–16, 2009.
- [12] M. Ciobotaru, P. Zanchetta, Y. De Novaes, and J. Clare, "A stationary reference frame current control for a multi-level H-bridge power converter for universal and flexible power management in future electricity network," *IEEE Power Electronics Specialists Conference, PESC 2008*, pp. 3943–3949, 2008.
- [13] S. Bifaretti, P. Zanchetta, and Y. Fan, "Power flow control through a multi-level H-bridge based power converter for Universal and Flexible Power Management in future electrical grids," *Power Electronics and Motion Control Conference, EPE-PEMC 2008*, 13th, pp. 1771–1778, 2008.
- [14] M. Ciobotaru, F. Iov, S. Bifaretti, and P. Zanchetta, "Short-circuit analysis of the UNIFLEX-PM using stationary and natural reference frame control," *EPE Journal: European Power Electronics and Drives*, vol. 19, no. December, pp. 42–50, 2009.
- [15] P. Cortés, M. P. Kazmierkowski, R. M. Kennel, S. Member, D. E. Quevedo, and J. Rodriguez, "Predictive Control in Power Electronics and Drives," *IEEE Trans. Ind. Electron.*, vol. 55, no. 12, pp. 4312–4324, 2008.
- [16] P. Cortes and J. Rodriguez, "Delay compensation in model predictive current control of a three-phase inverter," *IEEE Trans. Ind. Electron.*, vol. 59, no. 2, pp. 2011–2013, 2012.
- [17] P. Zanchetta and D. Gerry, "Predictive current control for multilevel active rectifiers with reduced switching frequency," *IEEE Trans. Ind. Electron.*, vol. 55, no. 1, pp. 163–172, 2008.
- [18] V. Biagini, M. Odavic, P. Zanchetta, M. Degano, and P. Bolognesi, "Improved dead beat control of a shunt active filter for aircraft power systems," *IEEE International Symposium on Industrial Electronics (ISIE 2010)*, pp. 2702–2707, 2010.
- [19] L. Tarisciotti, A. J. Watson, P. Zanchetta, S. Bifaretti, J. C. Clare, and P. Wheeler, "An improved Dead-Beat current control for Cascaded H-Bridge active rectifier with low switching frequency," *6th IET International Conference on Power Electronics, Machines and Drives (PEMD 2012)*, pp. 1–6, 2012.

- [20] M. Oettmeier, C. Heising, V. Staudt, and A. Steimel, "Dead-beat control algorithm for single-phase 50-kw AC railway grid representation," *IEEE Trans. Power Electron.*, vol. 25, no. 5, pp. 1184–1192, 2010.
- [21] P. Cortés, G. Ortiz, J. I. Yuz, J. Rodriguez, S. Vazquez, and L. G. Franquelo, "Model predictive control of an inverter with output LC filter for UPS applications," *IEEE Trans. Ind. Electron.*, vol. 56, no. 6, pp. 1875–1883, 2009.
- [22] Y. Pan and J. Wang, "Model Predictive Control of Unknown Nonlinear Dynamical Systems Based on Recurrent Neural Networks," *IEEE Trans. Ind. Electron.*, vol. 59, no. 8, pp. 3089–3101, Aug. 2012.
- [23] M. a. Perez, J. Rodriguez, E. J. Fuentes, and F. Kammerer, "Predictive Control of AC-AC Modular Multilevel Converters," *IEEE Trans. Ind. Electron.*, vol. 59, no. 7, pp. 2832–2839, Jul. 2012.
- [24] J. M. Espi, J. Castelló, R. García-Gil, G. Garcera, and E. Figueres, "An adaptive robust predictive current control for three-phase grid-connected inverters," *IEEE Trans. Ind. Electron.*, vol. 58, no. 8, pp. 3537–3546, 2011.
- [25] J. Barros, F. Silva, and E. Jesus, "Fast predictive optimal control of NPC multilevel converters," *IEEE Trans. Ind. Electron.*, vol. 60, no. 2, pp. 619–627, 2013.
- [26] S. Kouro, P. Cortés, R. Vargas, U. Ammann, and J. Rodriguez, "Model predictive control—A simple and powerful method to control power converters," *IEEE Trans. Ind. Electron.*, vol. 56, no. 6, pp. 1826–1838, 2009.
- [27] P. Cortes, A. Wilson, S. Kouro, J. Rodriguez, and H. Abu-Rub, "Model predictive control of multilevel cascaded H-bridge inverters," *IEEE Trans. Ind. Electron.*, vol. 57, no. 8, pp. 2691–2699, 2010.
- [28] R. Gregor, F. Barrero, S. L. Toral, M. J. Durán, M. R. Arahal, J. Prieto, and J. L. Mora, "Predictive-space vector PWM current control method for asymmetrical dual three-phase induction motor drives," *IET Electric Power Applications*, vol. 4, no. 1, p. 26, 2010.
- [29] F. Barrero, J. Prieto, E. Levi, R. Gregor, S. Toral, M. J. Durán, and M. Jones, "An Enhanced Predictive Current Control Method for Asymmetrical Six-Phase Motor Drives," *IEEE Trans. Ind. Electron.*, vol. 58, no. 8, pp. 3242–3252, 2011.
- [30] F. Barrero, M. R. Arahal, R. Gregor, S. Toral, and M. J. Durán, "One-Step Modulation Predictive Current Control Method for the Asymmetrical Dual Three-Phase Induction Machine," *IEEE Trans. Ind. Electron.*, vol. 56, no. 6, pp. 1974–1983, 2009.
- [31] Y. Zhang, W. Xie, Z. Li, S. Member, and Y. Zhang, "Model Predictive Direct Power Control of a PWM Rectifier With Duty Cycle Optimization," *IEEE Trans. Power Electron.*, vol. 28, no. 11, pp. 5343–5351, 2013.
- [32] Y. Zhang, Z. Li, Z. Piao, W. Xie, X. Wei, and W. Xu, "A novel three-vectors-based predictive direct power control of doubly fed induction generator for wind energy applications," *IEEE Energy Conversion Congress and Exposition (ECCE 2012)*, pp. 793–800, Sep. 2012.
- [33] G. Abad, M. Á. Rodriguez, and J. Poza, "Two-Level VSC Based Predictive Direct Torque Control of the Doubly Fed Induction Machine With Reduced Torque and Flux Ripples at Low Constant Switching Frequency," *IEEE Trans. Power Electron.*, vol. 23, no. 3, pp. 1050–1061, 2008.
- [34] Y. Zhang and J. Zhu, "Direct Torque Control of Permanent Magnet Synchronous Motor With Reduced Torque Ripple and Commutation Frequency," *IEEE Trans. Power Electron.*, vol. 26, no. 1, pp. 235–248, 2011.
- [35] P. Antoniewicz and M. P. Kazmierkowski, "Virtual-Flux-Based Predictive Direct Power Control of AC/DC Converters With Online Inductance Estimation," *IEEE Trans. Ind. Electron.*, vol. 55, no. 12, pp. 4381–4390, Dec. 2008.
- [36] S. Bifaretti, "Power flow control through the UNIFLEX-PM under different network conditions," *EPE Journal: European Power Electronics and Drives*, vol. 19, no. December, pp. 32–41, 2009.
- [37] M. Ciobotaru, R. Teodorescu, and F. Blaabjerg, "A new single-phase PLL structure based on second order generalized integrator," *IEEE 37th Power Electronics Specialists Conference, (PESC 2006)*, pp. 1–6, 2006.
- [38] A. Bellini and S. Bifaretti, "Performances of a PLL based digital filter for double-conversion UPS," *13th European Power Electronics and Motion Control Conference, 2008. EPE-PEMC 2008*, pp. 490–497, 2008.
- [39] S. Golestan, M. Monfared, F. D. Freijedo, and J. M. Guerrero, "Dynamics Assessment of Advanced Single-Phase PLL Structures," *IEEE Trans. Ind. Electron.*, vol. 60, no. 6, pp. 2167–2177, 2013.
- [40] S. Bifaretti, L. Tarisciotti, A. Watson, P. Zanchetta, A. Bellini, and J. Clare, "Distributed commutations pulse-width modulation technique for

high-power AC/DC multi-level converters," *IET Power Electronics*, vol. 5, no. 6, pp. 909–919, 2012.

- [41] L. Tarisciotti, A. J. Watson, P. Zanchetta, J. C. Clare, P. Wheeler, and S. Bifaretti, "A Novel Pulse Width Modulation technique with active DC voltage balancing and device voltage falls compensation for High-Power Cascaded multilevel active rectifiers," *IEEE Energy Conversion Congress and Exposition (ECCE 2012)*, pp. 2229–2236, 2012.
- [42] C. Cecati, A. Dell'Aquila, M. Liserre, and V. G. Monopoli, "A passivity-based multilevel active rectifier with adaptive compensation for traction applications," *IEEE Trans. Ind. Appl.*, vol. 39, no. 5, pp. 1404–1413, 2003.
- [43] J. Hu and Z. Zhu, "Improved Voltage-Vector Sequences on Dead-Beat Predictive Direct Power Control of Reversible Three-Phase Grid-Connected Voltage-Sourced Converters," *IEEE Trans. Power Electron.*, vol. 28, no. 1, pp. 254–267, 2013.
- [44] A. J. Watson, P. W. Wheeler, and J. C. Clare, "Field programmable gate array based control of Dual Active Bridge DC/DC Converter for the UNIFLEX-PM project," *14th European Conference on Power Electronics and Applications (EPE 2011)*, pp. 1–9, 2011.



Luca Tarisciotti (M'12) received the Master's degree in electronic engineering from The University of Rome "Tor Vergata" in 2009. He is currently working toward the Ph.D. degree in electrical and electronic engineering in the PEMC group, University of Nottingham. His research interests include multilevel converters, advanced modulation schemes, and advanced power converter control.



Pericle Zanchetta (M'00) received his degree in Electronic Engineering and his Ph.D. in Electrical Engineering from the Technical University of Bari (Italy) in 1993 and 1997 respectively. In 1998 he became Assistant Professor of Power Electronics at the same University and in 2001 he joined the PEMC research group at the University of Nottingham – UK, where he is now Professor in Control of Power Electronics systems. He is Vice-chair of the IAS Industrial Power Converters Committee (IPCC) and Associate Editor of the IEEE Transactions on Industry Applications and IEEE Transactions on Industrial Informatics.

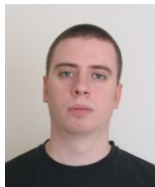

Alan Watson (S'03–M'07) received his MEng (Hons) degree in Electronic Engineering from the University of Nottingham in 2004, before pursuing a PhD in Power Electronics, also at Nottingham. In 2008, he became a Research Fellow in the Power Electronics Machines and Control Group, working on the UNIFLEX project (<http://www.eec.nott.ac.uk/uniflex/>). He is currently a Lecturer in High Power Electronics at the University of Nottingham. His research interests include the development and control of advanced high power conversion topologies for industrial applications, future energy networks, and VSC-HVDC.



Stefano Bifaretti (M'07) received the Laurea degree and the PhD degree in Electronic Engineering from University of Rome "Tor Vergata", Italy, in 1999 and 2003. In 2004 he became Assistant Professor at Department of Electronic Engineering of the University of Rome "Tor Vergata" where he is currently a lecturer in Power Electronics. In 2007 he was with the PEMC research group at the University of Nottingham (UK), collaborating on the UNIFLEX-PM European project. He has published over 70 papers in international journals and conferences. His research interests include power electronics converters, industrial drives and future electricity networks.



Jon C. Clare (M'90–SM'04) was born in Bristol, U.K. He received the B.Sc. and Ph.D. degrees in electrical engineering from the University of Bristol, U.K. From 1984 to 1990, he was a Research Assistant and Lecturer at the University of Bristol involved in teaching and research in power electronic systems. Since 1990 he has been with the Power Electronics, Machines and Control Group at the University of Nottingham, U.K., and is currently Professor in Power Electronics and Head of Research Group. His research interests are power electronic converters and modulation strategies, variable speed drive systems, and electromagnetic compatibility.