

Novel methodology for optimising the design, operation and maintenance of a multi-AGV system



Rundong Yan*, S.J. Dunnett, L.M. Jackson

Department of Aeronautical and Automotive Engineering, Loughborough University, Loughborough, Leics, United Kingdom

ARTICLE INFO

Keywords:

Automated guided vehicles
AGV
Coloured Petri nets
Maintenance
Reliability

ABSTRACT

Automated guided vehicles (AGVs) have long been identified as a potential driver to improve system efficiency and lower labour costs in material handling systems. Accordingly, the reliability and availability of AGV systems is crucial to assure the stability and efficiency of these systems. However, the reliability issues and maintenance strategies of AGVs have not previously been studied sufficiently. This is even more marked in the case of multi-AGV systems that consist of fleets of AGVs. To fill this knowledge gap, research is conducted considering a multi-AGV system, consisting of three AGVs, in order to develop a scientific methodology for optimising the layout design, operation and maintenance of a multi-AGV system. Once an AGV is failed, it will be towed to the maintenance site for repair by a recycle vehicle to prevent deadlock and conflict. The efficiency of the recycling process of failed AGVs in a multi-AGV system, with respect to the change of location of the maintenance site, is analysed by the approach of coloured Petri nets (CPNs). A CPN model simulating the corrective and periodic preventive maintenance processes of failed AGVs is also developed in order to investigate the impact of different AGV maintenance strategies on the operation efficiency of the multi-AGV system. The simulation results obtained clearly show that the location of maintenance sites and maintenance strategies do have significant influence on the performance of a multi-AGV system, where corrective maintenance is an effective measure to maintain the long-term reliability and stability of the system.

1. Introduction

Automated Guided Vehicles (AGVs), a type of vehicles that are driverless and programmed to travel on predefined routes to transfer loads, are being widely used in modern material handling systems due to their ability to improve the efficiency and productivity of the systems and decrease human labour. Accordingly, the design, operation and maintenance of the AGV systems have attracted interest from both academic and industrial communities in recent years. In particular work on improving the efficiency, and lowering the operation cost, of AGV systems has been performed [1, 2]. An approach was developed in [3] to obtain an optimal unidirectional flow path of AGVs. The optimal path design was targeted to minimise the total travel distance of the AGVs in the system. The main performance criteria for the guide-path material handling system were discussed in [4]. The interest of the majority of these pioneering works was focused on the optimization of the travel time and queue length of the AGVs. However, with the continual increasing application of AGVs, it is recognized that more factors should be taken into account to achieve an optimal solution for the design, operation and maintenance of an AGV system. For example,

the impact of empty AGVs on system operation was investigated in [5]. This research concludes that ignoring the impact of empty vehicles can lead to an underestimation of the number of AGVs and the time required for completing missions. Other attempts have been made to improve the system performance by various approaches. For example, a method was proposed in [6] to solve the deadlock problem, when AGVs are unable to make further progress, the potential in reducing both the material handling time and the cost was demonstrated by the approach of simulation. The impact of both empty and loaded vehicles on the operation of AGV system was researched in [7] in order to optimise the direction of unidirectional routes.

With the continual scaling up and modernisation of AGV systems in recent years, they are now designed to deliver more complex tasks. Accordingly, more and more uncertainty issues are observed in the systems. For this reason, the failure management and maintenance strategies of AGVs are identified as new challenging issues that need to be addressed. As the rate of application of AGVs continues to increase the need to resolve such issues has become a pressing task. Some studies have been undertaken in the literature to achieve this. For example, the safety requirements and safety functions for a decentralised controlled

* Corresponding author.

E-mail address: r.yan@lboro.ac.uk (R. Yan).

<https://doi.org/10.1016/j.ress.2018.06.003>

Received 25 September 2017; Received in revised form 5 May 2018; Accepted 1 June 2018

Available online 03 June 2018

0951-8320/© 2018 The Authors. Published by Elsevier Ltd. This is an open access article under the CC BY license

(<http://creativecommons.org/licenses/by/4.0/>).

AGV system were discussed in [8]. In this work, three major hazards, i.e. collision with a person, tilting over and falling down, were identified. The effects of the speed of AGVs, the braking distance and detection area requirements, as well as the mean time to dangerous failure and performance were analysed. Considering failure response, a control method was developed in [9] for enhancing the failure control management of a special case of AGVs, an underground transportation system. In the research, both loaded and unloaded AGVs were considered. More recently, the reliability of AGVs was modelled as a cost function to optimise the time and cost of the operation of AGVs [10]. All of these studies have shown that the reliability and efficiency of AGV systems can be achieved at the same time. However, to the best knowledge of the authors, the availability of AGVs and its influence on the efficiency and performance of the system has never been discussed before. This motivates the research studied in this paper.

The availability of a system can be guaranteed via conducting appropriate maintenance, in which either major or minor repairs or even replacement of defective components would take place. At present, preventive, corrective and predictive maintenance are primary maintenance strategies that are popularly adopted in engineering practice. Usually, preventive maintenance is conducted periodically despite the actual health condition of the AGVs. In contrast to the former, corrective maintenance is conducted only when a failure is present in the AGV. Predictive maintenance monitors the state of components/subsystems in order to determine the optimal maintenance time. These maintenance strategies, their merits and constraints, as well as their influences on system availability have been investigated in other industries [11, 12]. For example, different maintenance policies for manufacturing production lines were simulated in [13] and the maintenance cost and the availability of an aircraft system were optimized in [14]. Given the lack of research on the impact of maintenance activities on the availability of AGV systems, in this research, two different maintenance strategies, namely preventive and corrective maintenance, for multi-AGV systems are considered. Their different contributions to the system efficiency and availability are investigated. The predictive maintenance is not considered in this research because (1) it has not been a proven technology in the application of AGVs due to the difficulty of obtaining reliable remaining life prediction of the AGV components under the constantly varying conditions they operate in; (2) neglecting predictive maintenance behaviour simplifies the simulation model thus making the methodology described here easier to follow. However using the approaches outlined in this work predictive maintenance could be built into the model. Once an AGV has failed in the system, it should be recycled as soon as possible to prevent further deadlock and conflict. When modelling the multi-AGV system, the automatic recycling of a failed AGV, i.e. the use of an additional AGV to collect the failed AGV and transport it to the appropriate site, and its travelling path in the system, are considered in order to reduce the human's intervention in the operation of the system. A specific area for storing the failed AGV and the maintenance plan are considered when modelling the multi-AGV system. In this way, the influences of the location of the maintenance site and maintenance plan of the failed AGV on the system efficiency can be investigated through modelling the system using coloured Petri nets (CPNs). Such comprehensive research paves the way to achieve more successful layout design, operation and maintenance of multi-AGV systems. To the best of the authors' knowledge, CPNs have never been applied to the study of the reliability, operation, mission and maintenance of AGVs and AGV systems. Hence the aim of the work presented in this paper is to demonstrate the advantages of applying this modelling technique to this area. Also, the technique has been adapted in this work and a novel approach is adopted using five different types of nets which interact to provide the overall system availability. Adopting this approach makes the method very versatile and it can be easily modified if the requirements or missions change.

The remaining part of this paper is organised as follows. The CPN

modelling methods are discussed first in Section 2; the configuration of the AGV system & mission of interest are described in Section 3; All CPN based models for describing the multi-AGV systems, recycle and maintenance behaviours are established and simulated respectively in Sections 4 and 5; the simulation calculations and result discussions are performed in Section 6; and the paper is finally completed with a few key research conclusions in Section 7.

2. Methodology for modelling recycling and maintenance processes

Due to its efficient and cost effective nature, modelling has been identified as an important approach to improve the design, operation and maintenance of an AGV system. However, any model developed would need to be dynamic and highly adaptive. Since Petri nets (PNs) provide an intuitive graphical representation of a system, and allow flexible description of any event caused by the modification of design, operation and maintenance of a system, they are adopted to model the problem considered in the paper.

The concept of a PN was developed by Petri [15], and it is defined as a direct bipartite graph that consists of four types of symbols: circles, rectangles, arrows and tokens, as shown in Fig. 1. Circles represent the places, which are conditions or states such as mission failure, phase failure, or component failure; rectangles represent the transitions, more abstractly actions or events which cause the change of condition or state. It should be mentioned that if the time for completing the transition is zero, the rectangle is filled in, otherwise it is hollow; arrows represent arcs which are connections between places and transitions. Arcs with a slash on and a number, n , next to the slash represent a combination of n single arcs and the arc is said to have a weight n . No slash always means that the weight is one; and small filled in circles represent tokens which carry the information in the PNs. The tokens move via transitions as long as the enabling condition is satisfied, which gives the dynamic properties of the PN. For example in Fig. 1, there are two and three tokens (represented by small filled in circles) in each of the two input places to the transition. The input places have arcs with weights 1 and 3, respectively. The transition is said to be enabled since the number of tokens contained in every input place is equal to or greater than the corresponding arc weights. As the transition is enabled after the time associated with the transition, t , the number of tokens equivalent to the arc weights are taken out of the input places and the number of tokens equivalent to the output arc weight are transferred to the output place. In this example one token appears in the output place as shown in Fig. 1.

The marking of a net at any particular time gives the state of the system being modelled at that time. Due to the strengths of the PN approach in describing systems the technique has been widely applied to modelling a variety of systems. For example, a hybrid PN modelling method coupled with parameter trend which prescribes thresholds and allowable margins of fault places, and fault tree analysis has been applied to model the maintenance policy of heating and cooling systems in [16] and functional product availability and support cost were predicted by using fault tree, Petri net and discrete event simulation techniques in combination in [17]. The maintenance of an offshore wind turbine was modelled by using PNs in [18] where, three types of different maintenance strategies, namely periodic, conditional and

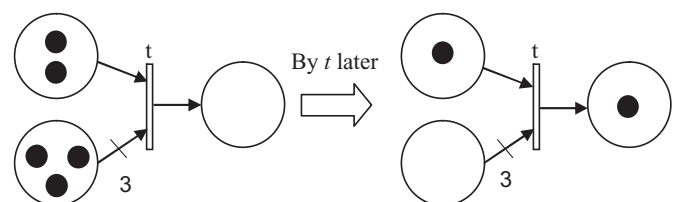

Fig. 1. Petri net model with transitions.

corrective were modelled in detail. These works have showed the strength and effectiveness of PN simulation for maintenance modelling.

However, conventional PN methods have been shown to have difficulty in describing complex systems or a system that is designed to carry out complex tasks or missions [19]. To address this issue, an extension of the PN method, namely Coloured Petri nets (CPN), was introduced in [20]. In comparison with the classical PN, each individual token in the CPN is designed with a specific colour, which either has different identities or carries different information. Therefore, they are more informative in contrast to those present in the classical PN. These colours are also associated with transitions so that the transitions can be activated if and only if the tokens with the same colour are present in the model.

3. Configuration of the AGV system & mission of interest

The AGV transport system described in [21] is considered in this research. However, instead of considering a single-AGV system as was the case in [21], a multi-AGV system consisting of three AGVs is investigated. Although the number of AGVs considered is low it allows the complexities of a fleet to be considered and demonstrated. The methods adopted can be used for fleets of any number. This could be achieved by dividing large AGV systems into small sections, basic elements, using a grid. By analysing the basic element route structure and the interactions between them, the analysis and simulation of large AGV systems can be simplified and achieved. Using the approach adopted here it is possible to consider the structure of the AGVs and model the subsystems as shown in [21] however as the main aim of this work is to model the maintenance and operation of multi-AGV systems it was decided to consider the AGVs as single systems with an assumed failure rate of 12 failures per year. The failure rate is deduced from [21] which is the total number of failures per year of all the subsystems in each AGV. Different from a single AGV system, a multi-AGV system requires the investigation of the interactions between different AGVs and the influences of the failure of one or more AGVs on the operation of the others in the same system. As described in [21], the mission of the AGVs can be divided into six phases, namely (1) mission allocation and route optimisation, (2) dispatch to station, (3) loading of item, (4) travelling to storage, (5) unloading and (6) travelling back to base. In order to facilitate the research, the length of each phase has been assumed and listed in Table 1. In the model, it is assumed that the failed AGV will be removed from the system as soon as possible to prevent deadlock and conflicts, so that the downtime of the system due to the failure of AGV can be minimised. To meet such a requirement, an optimal location of the maintenance site is essential, from where a recycle vehicle, the vehicle used to bring the failed AGV to the maintenance site, is sent out and able to recycle the failed AGV.

4. Modelling a multi-AGV system

To maintain the desired availability of individual AGVs and the reliability of a multi-AGV system, an optimal maintenance strategy and the optimisation of maintenance site location are essential. To explore a solution for this problem, CPN models of a multi-AGV system and the

Table 1
Assumed phase lengths.

| Phase | Phase Length Hour |
|--|----------------------|
| Phase 1: Mission Allocation & Route Optimization | 0.02 |
| Phase 2: Dispatch to Station | 0.2 |
| Phase 3: Loading of Item | 0.02 |
| Phase 4: Travelling to Storage | 0.2 |
| Phase 5: Unloading | 0.02 |
| Phase 6: Travelling Back to Base | 0.2 |

associated AGV maintenance strategies are developed in this research. These models are used to investigate the influence of AGV maintenance strategies and the location of maintenance sites on the operation performance of the system. In the present research, the operation performance is indicated by the system operation cost and the number of missions that the system delivers within a given time.

In a multi-AGV system, each AGV should be distinguishable as they are located at different positions in the system and could fail at different times. Due to the powerful capability of CPNs in describing such situations [22, 23], this approach is employed in this research.

To accurately describe the actual operation and maintenance activities in a multi-AGV system, five innovative CPN models are established in this research. They are:

- (1) Path Petri nets (PPN) – for describing the layout configuration of the system;
- (2) Master Petri nets (MPN) – for governing the mission progress or phase change of individual AGVs in the system;
- (3) Recycle Petri nets (RPN) – for describing the recycle process of failed AGVs;
- (4) Corrective maintenance Petri nets (CMPN) – for defining the corrective maintenance of failed AGVs in the system;
- (5) Periodic maintenance Petri nets (PMPN) – for defining the periodic maintenance of all AGVs in the system.

Although the aforementioned five CPN models are described separately below they are linked and pass information between each other. The PPN and MPN are linked together so that the flow of AGVs in the system and their allocated missions are correlated simultaneously. The MPN feeds the information into the RPN to enable the recycle process. In addition, the CMPN and PMPN share the AGV failure information and feed their responses into the MPN and PPN.

4.1. Path Petri nets (PPNs)

To demonstrate the significant influence of layout configuration on the efficiency of recycling failed AGVs from a multi-AGV system, three different layout configurations of a three-AGV system are considered as shown in Fig. 2. In a typical AGV mission, an AGV starts from its base and travels to a pickup station to collect materials. It then travels to its destination, storage, to unload the material and finally back to base to complete the mission. Hence each of the examples considered consists of an AGV base, a pickup station, a storage site, a maintenance site, and a number of transport paths. The base is for storing and recharging the AGVs; the pickup station is the place where items are collected; and storage is the destination for unloading the items. Every place is assumed to allow the parking of multiple AGVs. In Fig. 2 MS indicates the location of the maintenance site. Although the configurations shown in Fig. 2 are very simple with only 3 or 4 places they do contain all the basic elements of a typical AGV's mission. They have been considered here in order to clearly describe the methodology adopted. As mentioned in Section 3 this methodology can easily be extended to consider larger and more complex configurations.

From Fig. 2, it is seen that different layout configurations are distinguished by different locations of the maintenance site and extra paths required to deliver recycling tasks. For example, the maintenance site shares the same space with the base in Fig. 2a; in Fig. 2b, the maintenance site is located between the base and the storage. In addition, an extra path between the pickup station and the maintenance site is designed to prevent deadlock due to failure; in Fig. 2c, the maintenance site is located in the centre of the system. Accordingly, three extra paths are designed to assure its accessibility to failed AGVs that could happen anywhere in the system. The time required to travel on the extra paths can be obtained geometrically by neglecting the size of the stations. Based on the above descriptions, the PPN models for these three different layout configurations can be readily constructed

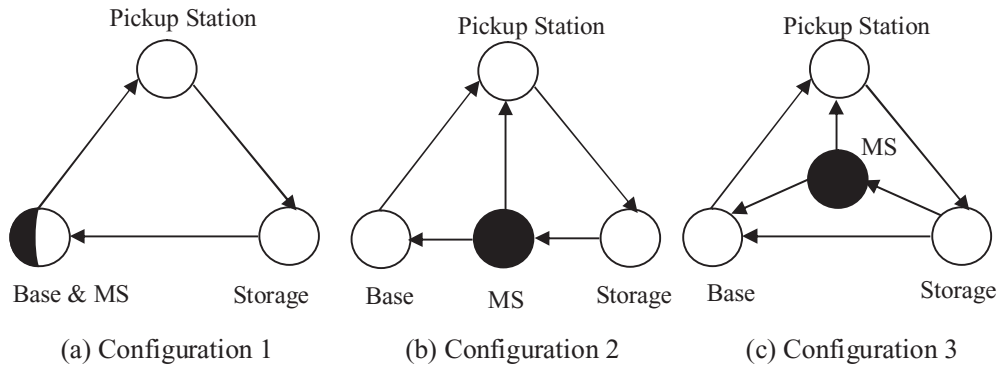

Fig. 2. Examples of layout configuration.

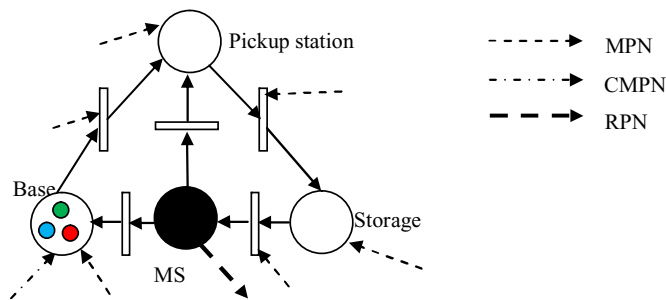

Fig. 3. PPN of configuration in Fig. 2b.

by defining the directions of movement of the AGVs. An example of the PPN for the configuration shown in Fig. 2b, with one direction of movement enabled only, is shown in Fig. 3. In the figure the dotted arrows represent information flows from three different PNs. The MPN links the path with the mission; the RPN is connected to locate the failed AGVs and find the optimal recycle route; and the CMPN to send the failed AGV back to the base.

4.2. Master Petri nets (MPNs)

The MPN model is developed to govern the change of phases from the beginning of the mission, Phase 1, to the successful completion of the whole mission, at the end of Phase 6. Fig. 4 shows the structure of the MPN. The coloured tokens in the MPN represent the different AGVs and are initially in the ‘Base’ place in the PPN models. Once a mission starts for an AGV its token will move into the phase 1 place. If the token representing an AGV resides in place ‘Phase i’ it indicates that the AGV is in that phase of its mission. The failure of an AGV will result in the

failure of its mission.

The MPN model and the relevant PPN model will be used in combination to describe the mission and AGV routing problem. As an example the combined PPN-MPN model adopting layout 1 from Fig. 2b is shown in Fig. 5.

From Fig. 5, the integration of the 2 nets is clearly exhibited. The tokens inside the ‘Base’ place indicate that AGVs are free to be allocated to missions. The AGVs in the base have the same probability to be selected for a particular mission. It is worth mentioning that only the same coloured tokens in the places of both the PPN and MPN can enable the transitions. Hence, the movement of AGVs and their working phases can be correlated together.

Initially, three tokens representing the AGVs are in the ‘Base’ place. Once an AGV starts its mission the corresponding token will move from base into P1 in the MPN after the delay associated with this phase. Also, a same coloured token will be returned to the base as indicated by the bidirectional arrow between the place ‘Base’ and the transition ‘Delay’ in the MPN because the AGV has not started to physically move. Once the token flows to the ‘P2’ phase place in the MPN then the transition between the ‘Base’ and the ‘Pickup station’ in the PPN is enabled. After the delay associated with travelling between the base and the station has expired this transition will fire and the appropriate token will move into the ‘Pickup station’ place. A token will also be returned into the ‘P2’ place. The transition between the places ‘P2’ and ‘P3’ in the MPN is now enabled and hence the token will move between ‘P2’ and ‘P3’ modelling the progression of the phases. The tokens in the network will flow continuously until the mission is completed and AGVs travel back to the base and start new missions. Once an AGV fails, the corresponding token for that AGV will reside in the place ‘Down’. This will enable the transition to the ‘Mission failure’ place in the MPN, indicating the termination of the mission of that AGV. The ‘Mission

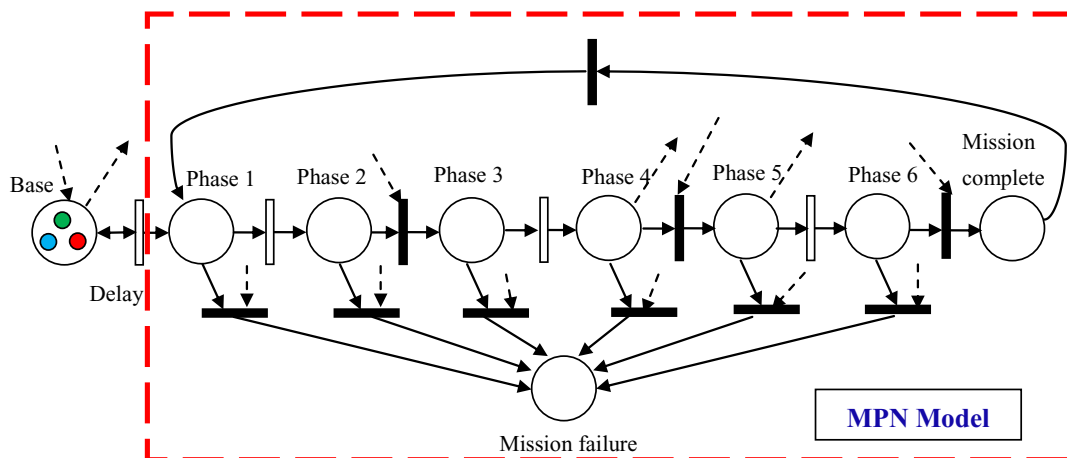

Fig. 4. MPN model.

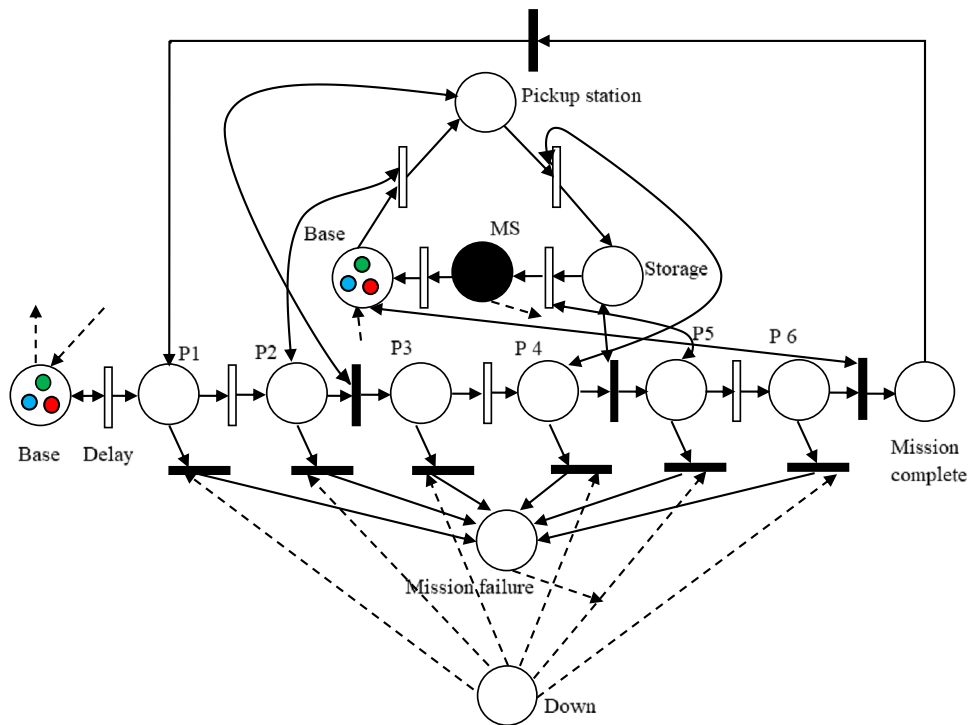

Fig. 5. PPN-MPN model.

failure' place is connected to the RPN, so that the token given to the place can enable the RPN to start the recycle process. The switching time of a transition between two neighbouring phase places is the length of the preceding phase. Likewise, the switching time of a transition between two places in the PPN is the travel time between the stations. If the AGV completes all 6 phases without failure then a token will be placed in the 'Mission complete' place.

Initially, each AGV is activated one by one randomly with a time delay of 0.22 hours. This time gap is greater than the time to complete a single path between 2 sites. Hence, each path will have at most one AGV on it throughout the mission. Such timings help prevent deadlock of the system.

4.3. Recycle Petri nets (RPNs)

Once an AGV fails, the recycling of the failed AGV will be activated immediately. First of all the position of the failed AGV will be located. Failure location is a place defined to be at the location of the failed AGV. Hence once an AGV fails, a new place for failure location will be generated based on the time the AGV has travelled since leaving its last place. For example, when an AGV fails between the pick station and the storage, a place of failure location will be generated as shown in Fig. 6.

Then, the route for the recycle vehicle will be optimised. The method of optimising the route is described below. As shown in Fig. 7, during the process of recycling if any AGV is found running on the optimised route, the recycle vehicle will not leave the maintenance site until that AGV reaches its next station. After that AGV reaches the station, it will park there and be off the route until the failed vehicle is recovered, so that the recycle route is unblocked. The other AGVs that are not running on the optimised route will stop and stay at their

current positions in order to avoid potential blockage. After the recycle vehicle reaches the position of the failed AGV, it will tow the failed AGV back to the maintenance site. The token in 'stop all AGVs' produced due to the AGV failure will be removed after reaching the failure location, so that the system is activated again. Due to the fact that the maintenance site can be reached by following the flow of working AGVs, the system can be restarted immediately the recycle AGV has collected the failed AGV. Hence, all the other AGVs will resume their tasks. The transition between the places, 'maintenance site' and the 'failed AGVs recycled' can be enabled only if the token representing the recycle vehicle with the towed failed AGV is in the maintenance site place.

As mentioned above, the recycling of failed AGVs will disturb the normal operation of other AGVs running on both the recycling route and non-recycling routes, hence the routing of recycling is critical to the whole performance of the multi-AGV system. Therefore, it is very important to optimise the recycling route to ensure the availability of AGVs and the operation efficiency of the multi-AGV system.

In order to demonstrate the identification of the optimal recycling route, the layout configuration shown in Fig. 2b is expressed using a matrix as shown below. The variables in the matrix are defined in Fig. 8.

$$\begin{matrix}
 & A1 & A2 & A3 & A4 & A5 \\
 S1 & \begin{bmatrix} 1 & 0 & 0 & 1 & 0 \end{bmatrix} \\
 S2 & \begin{bmatrix} 1 & 1 & 0 & 0 & 1 \end{bmatrix} \\
 S3 & \begin{bmatrix} 0 & 1 & 1 & 0 & 0 \end{bmatrix} \\
 S4 & \begin{bmatrix} 0 & 0 & 1 & 1 & 1 \end{bmatrix}
 \end{matrix} \tag{1}$$

In the matrix, the rows and columns respectively represent the stations and the paths in the system. The number '1' indicates the availability of direct connection between a station and a path, while the

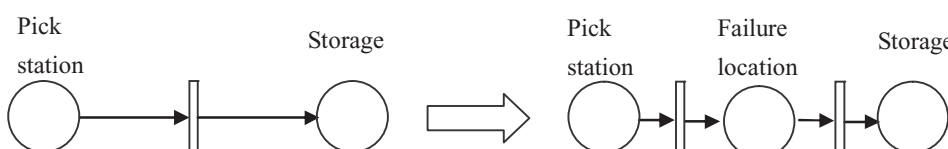

Fig. 6. Generation of failure location.

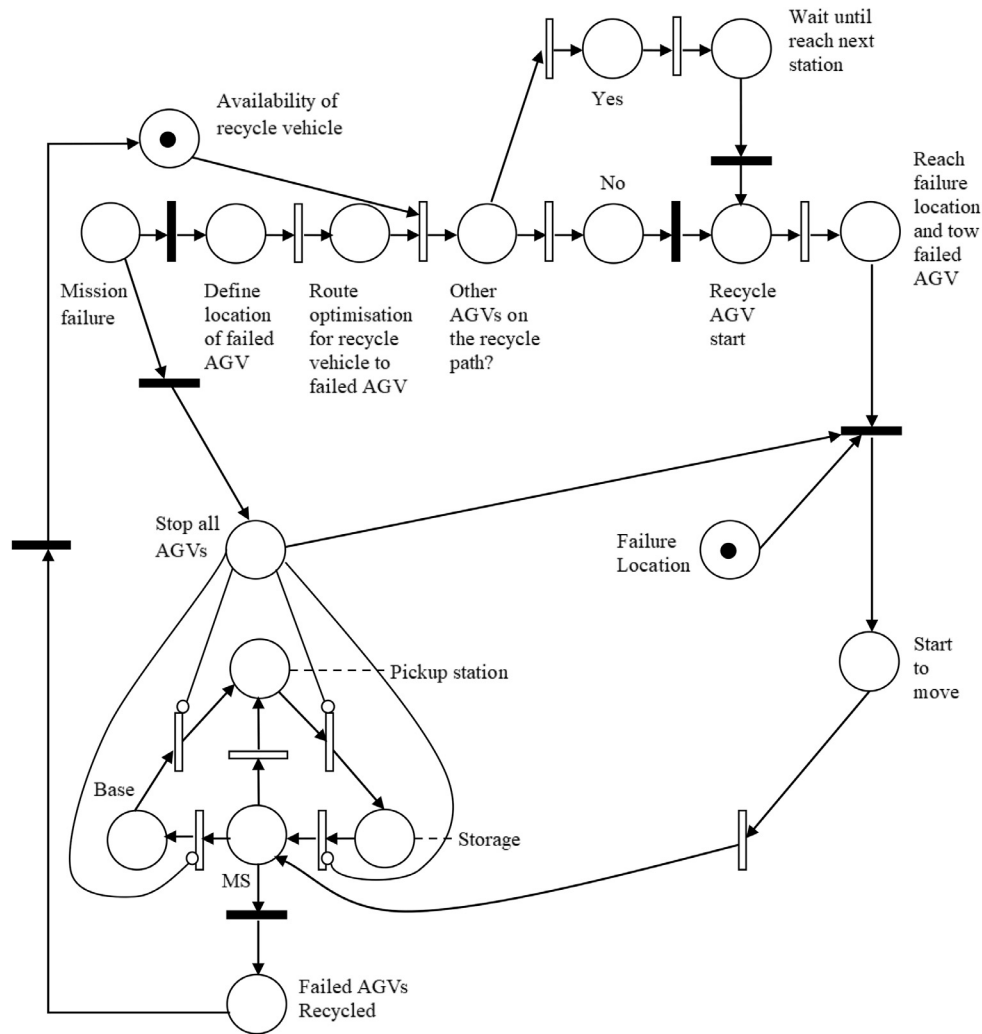

Fig. 7. RPN model.

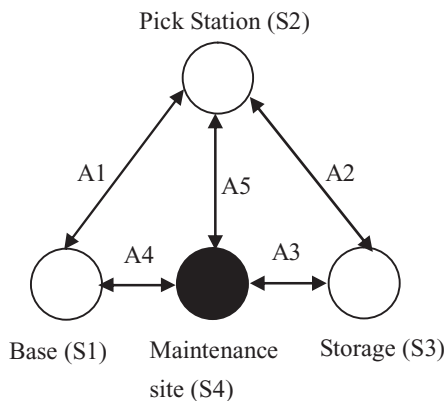

Fig. 8. Definition of variables in matrix.

number ‘0’ indicates the unavailability of direct connection between a station and a path. With the aid of a searching algorithm, the recycling routes passing through the least number of stations can be obtained. For example, starting from the maintenance site, S4 in Fig. 8, its connectivity to route A3, A4 and A5 can be identified using the matrix in equation (1). By repeatedly searching the connectivity of stations and routes and eliminating those already searched, the location of the failure AGV can eventually be reached. Hence in the example considered the routes A3, A4 and A5 are all checked to see if the failed AGV

is on any of these routes and if so which station it is closest to. If it is not on any of these routes the algorithm checks the columns in the matrix corresponding to A3, A4 and A5 and determines the other stations on the routes and checks if the breakdown is at any of these stations. The algorithm continues in this manner until the breakdown is located. Such a method is relatively simple and can be easily implemented compared with other algorithms such as stochastic search and tree search. It is worthy to note however that this method could get computational expensive once the system size becomes large. In this case more constraints such as, restricted travel direction and specified stations and routes, can be supplemented to simplify the computation. If the obtained recycling routes pass through the same number of stations, further searching needs to be conducted to identify the recycling route with the shortest distance. To ease understanding, an example is given in Fig. 9 where possible recycling routes are shown for the case when an AGV is assumed failed during Phase 2. To facilitate description, RT is defined as the actual operation time before failure of the AGV during the mission, P1L is the time for completing the actions of Phase 1, P2L is the time for completing the actions of both Phase 1 and Phase 2, and L4 and L5 are respectively the time that AGV will take to complete routes A4 and A5. In Phase 2, the AGV is travelling from the base to the pickup station and from Fig. 9, it is observed that two recycling routes passing through the same number of stations have been identified from the matrix. While, the route, S4 → A4 → S1 → Failure Location, has shorter distance than the route, S4 → A5 → S2 → Failure Location. Thus, the route S4 → A4 → S1 → Failure Location, is regarded as the best

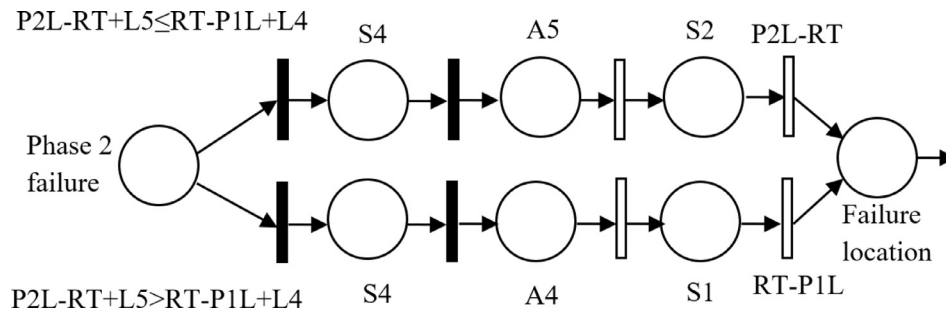

Fig. 9. The search of the shortest distance.

recycling route.

4.4. Corrective maintenance Petri nets (CMPNs)

On arriving at the maintenance site, the failed AGVs will enter into the corrective maintenance process immediately, and will be repaired as soon as a maintenance engineer is available. However, if all maintenance engineers are unavailable the failed AGVs will have to wait in a queue. After the corrective maintenance has been performed the recovered AGV will be assumed to be as good as new. At that time, the maintenance engineer who undertakes the repair of that AGV will be released and will become available again. In the model, a normal distribution function is employed to describe the repair time of the failed AGVs. The CMPN model developed is shown in Fig. 10.

4.5. Periodic maintenance Petri nets (PMPNs)

To describe periodic maintenance a PMPN model has been developed and is shown in Fig. 11. In the model, after the maintenance has been performed it is assumed that the health condition of all AGVs in the system is as good as new.

From Fig. 11, it is worth noting that in the model the three transitions with different colours correspond to the failure time of the three AGVs in the system. All the AGVs including both failed and functional ones, will undergo the periodic maintenance process for a predefined fixed maintenance time, which is assumed 2 days in this paper. For example in Fig. 11, m AGVs are in good health state and n AGVs have failed, then the total of $m + n$ of AGVs will undergo a periodic maintenance process. It is assumed that the system will start to operate for the production of the next period as soon as the duration of periodic maintenance expires.

5. Simulation model

By integrating the five different CPN models described in Section 4, a model has been constructed to describe the layout configuration, recycling and maintenance processes of a multi-AGV system. To facilitate simulating the maintenance process in this work the models have been

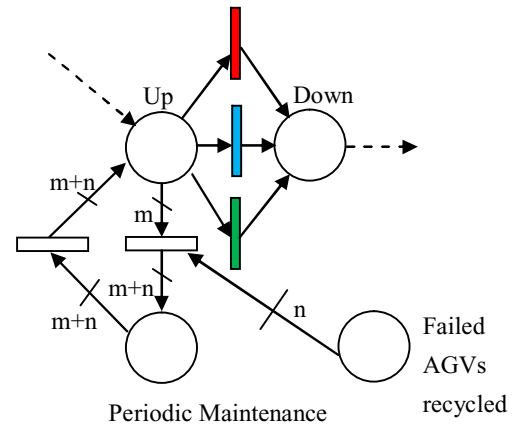

Fig. 11. PMPN model.

fully coded in Python. Each CPN model is programmed separately and linked together for simulation. All of the parameters can be modified to fit other applications if necessary. To verify the model and investigate the influences of different layout configurations and maintenance strategies on the operational performance of a multi-AGV system, software has been developed to simulate the model. The failure rate and repair rate of all AGVs, the time taken to perform the periodic maintenance, and the phase lengths are used as inputs of the model. The simulation procedure is implemented by following steps:

Step 1: Initialise the model by

- (1) defining the values of the timed transitions representing the phase lengths in the MPN and the PPN using Table 1;
- (2) generating the switching times of the transitions for each AGV in the PMPN by using random sampling and the exponential distribution method;
- (3) setting the time interval of the periodic maintenance in the PMPN;
- (4) placing three coloured tokens in the 'Base' place initially, and one token in each 'AGV up' place to show that all AGVs are assumed to be in 'healthy' state at the start.

Step 2: Identify and switch the transition with the minimum switching time in the whole model;

Step 3: Search through the immediate transitions that are directly connected to the present output place switched. If any are found enabled, switch them;

Step 4: Repeat Step 3 until no more immediate transitions are enabled;

Step 5: Check the condition of 'Is corrective maintenance adopted?', If 'Yes', only check whether the given time expired or not, log it and start next simulation; if 'No', check both the given time and the health condition of all AGVs. If either the given time expired or the all AGVs have failed, log it and start next simulation;

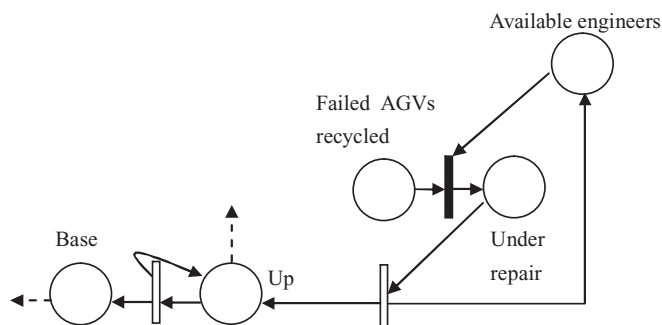

Fig. 10. CMPN model.

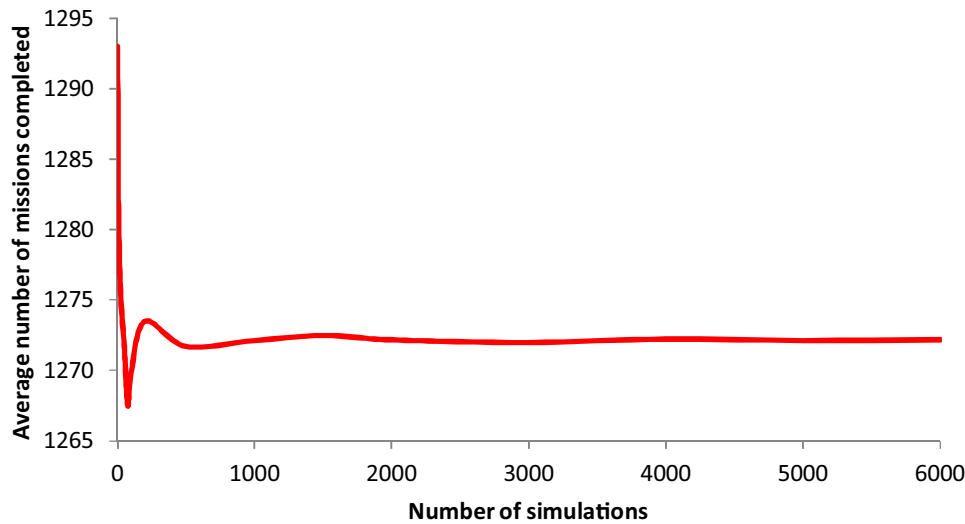

Fig. 12. The average number of missions completed in one month when the time interval of periodic maintenance is one month.

Step 6: Iterate the above simulation until iteration time reaches 10,000.

A single-AGV system model has been validated using fault tree analysis by Yan et al. [21]. Since the multi-AGV system model considered in this paper is based on this earlier model, further validation is not necessary. In order to validate the convergence of the model the average number of missions completed within one month when the time interval of periodic maintenance is one month and the layout in Fig. 2b is adopted, is calculated as an example. The results are plotted in Fig. 12.

From Fig. 12, it is found that the average number of missions completed fluctuates at the beginning when the number of simulations is small. Then, it starts to converge gradually with the increase of simulations and finally reaches a stable value after approximately 4,000 simulations. This value depends on the parameters used in the model, such as the reliability of the AGVs, the time interval of the periodic maintenance, lengths of paths etc. In this research, to ensure the reliability of the results, 10,000 simulations are taken in the following calculations.

6. Factors influencing the performance of a multi-AGV system

Initially the influence of the different layout configurations considered on the recycle time of failed AGVs is investigated. It is assumed that having a separate maintenance site as shown in Figs. 2b and c, will decrease conflict and deadlock while increasing the efficiency of the recycle process although it will require extra space and extra routes in the facility in which the AGVs operate. The results are shown in Table 2. From the table, it is found that when the maintenance site is placed in the centre as indicated by Fig. 2c, the shortest recycle time is achieved. However, extra space and the longest length of extra route will be required in such a layout configuration. When the maintenance site is placed at the AGV base (see Fig. 2a), the system does not require extra space and there is no need to build extra routes for implementing the

Table 2
Recycle time.

| Location indicated by | Recycle Time (hours) | Extra Space (unit) | Length of extra route required (unit) |
|-----------------------|----------------------|--------------------|---------------------------------------|
| Fig. 2a | 0.13162 | 0 | 0 |
| Fig. 2b | 0.12851 | 1 | $\sqrt{3}/2$ |
| Fig. 2c | 0.10075 | 1 | $3\sqrt{3}/4$ |

recycling service however at the price of the longest recycle time. The increased recycle time might be a result of the assumption that the recycle process can start only if there are no other AGVs running on the recycle path. When the maintenance site is placed between the AGV base and the storage (see Fig. 2b), extra space is required with the compromised values of recycle time and the length of an extra route. From these simulation results, it can be seen that the location of the maintenance site is critical in the design of a multi-AGV system as it has significant influence on the recycling efficiency and extra space and route requirements. Therefore, the optimisation of the maintenance site location is essential in the design of a multi-AGV system.

The influence of different maintenance strategies on the performance of the multi-AGV system is also investigated. By assuming the operation time of the system is 10 hours every day and the configuration layout illustrated in Fig. 2b is adopted, the corresponding results are shown in Table 3 which shows the number of missions completed when different maintenance strategies are applied. From Table 3, it is found that

- for the system that does not consider any maintenance, 98% of all AGVs would fail within 12 months, or 3280 missions. This necessitates the measures for conducting appropriate maintenance of the AGVs during their service. The number of completed missions will increase if the AGVs receive periodic maintenance service. From the simulation results obtained, doing periodic maintenance once every 20 days gives the best throughput which means 13,213 missions can be done in a year. Usually, AGV manufacturers and suppliers

Table 3
Number of Missions.

| T | P | N1 | N2 |
|-----------|-------|--------|--------|
| 7 days | 0.03 | 11,518 | 11,840 |
| 20 days | 1.10 | 13,213 | 14,709 |
| 1 month | 3.93 | 12,840 | 15,264 |
| 2 months | 18.06 | 11,028 | 15,792 |
| 3 months | 36.32 | 9372 | 15,972 |
| 4 months | 53.37 | 7983 | 16,059 |
| 6 months | 77.34 | 6084 | 16,142 |
| 12 months | 98.06 | 3280 | 16,234 |

Note: T – Time interval of periodic maintenance; P – Percentage of AGVs failed within the time interval if there is no maintenance (%); N1– Number of missions completed per year with periodic but without corrective maintenance; N2– Number of missions completed per year with both periodic and corrective maintenance.

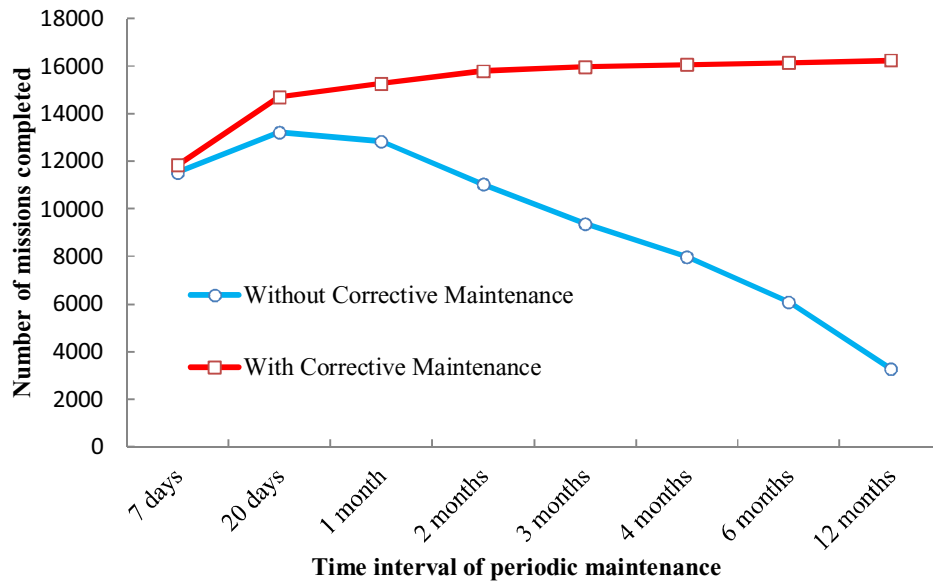

Fig. 13. Missions completed per year.

provide 2 to 6 planned maintenances every year. For the system analysed in the example, only 6084 missions can be completed if there are 2 occurrences of maintenance in a year. This means that over 7000 missions cannot be completed. However, the time interval of the periodic maintenance will also affect the number of missions completed within the given time, i.e. the number of missions completed will decrease if the AGVs receive too frequent periodic maintenance.

- Corrective maintenance can enhance the performance of the multi-AGV system, i.e. the corrective maintenance can help to keep long-term high efficiency of the system (see Fig. 13), although it could induce additional financial and labour costs.

From the simulation results, it can be concluded that both the location of the maintenance site and maintenance strategies have significant influence on the performance of the multi-AGV system. Therefore, they should be optimised in the design of the system.

7. Conclusions

In order to develop an efficient and reliable approach to find the optimal design, operation, and maintenance strategy of a multi-AGV system, CPN simulation models are developed in this research.

From the research results described above, the following conclusions can be drawn.

- The CPN method has been demonstrated a valid approach for conducting multi-AGV system mission performance assessment and evaluating the AGV routing in the system.
- Adopting the CPN methodology both tokens and transitions can be allocated specific properties using colour. Hence, more functions of CPN can be developed and the CPN model constructions can be simplified. For example, tokens in the model can be given specified missions or switches with special conditions can be modelled.
- The CPN method enables the influence of maintenance and the optimal time for periodic maintenance to be evaluated. It has been demonstrated that the location of a maintenance site and maintenance strategies do have significant influence on the performance of a multi-AGV system, thus, it is necessary to optimise them in the design.
- The corrective maintenance is indeed an effective measure to maintain long-term high efficiency of the system, although it would

cause additional maintenance cost.

This research filled the research gap about the reliability and maintenance of multi-AGV systems. A methodology has been developed to model the design, operation, and maintenance strategy of a multi-AGV system. Future work will extend the model to include other relevant maintenance activities, such as predictive maintenance. Also, the methodology outlined in this paper can be scaled up to model larger and more complex AGV systems. This could be achieved by dividing the systems into small basic operation elements. By investigating the layout structure of the basic elements and interactions between them, the simulation of the complex systems could be performed. Moreover, the approach developed in this paper could also be easily adapted to model the maintenance of other fleets of vehicles, such as buses or lorries.

Acknowledgement

The work reported in this paper aligns to the working being researched as part of the EPSRC grant EP/K014137/1.

References

- [1] Tuan L-A, De Koster MBM. A review of design and control of automated guided vehicle systems. *Eur J Oper Res* 2006;171(1):1–23.
- [2] Vis IF. Survey of research in the design and control of automated guided vehicle. *Eur J of Oper Res* 2006;170(3):677–709.
- [3] GASKINS RJ, TANCHOCO JMA. Flow path design for automated guided vehicle systems. *Int J Prod Res* 1987;25(5):667–76.
- [4] Beamon B. Performance, reliability, and perform- ability of material handling systems. *Int J Prod Res* 1998;36(2):377–93.
- [5] Johnson ME. Modelling empty vehicle traffic in AGVS design. *Int J Prod Res* 2001;39(12):2615–33.
- [6] Bhattacharya R, Bandyopadhyay S. An improved strategy to solve shop deadlock problem based on the study on existing benchmark recovery strategies. *Int J Adv Manufact Technol* 2000;47(1):351–64.
- [7] Kaspi M, Kesselman U, Tanchoco J. Optimal solution for the flow path design problem of a balanced unidirectional AGV system. *Int J Prod Res* 2002;40(2):389–401.
- [8] Trenkle A, Seibold Z, Stoll T. Safety Requirements and Safety Functions for Decentralized Controlled Autonomous Systems. 2013 XXIV International Conference on Information, Communication and Automation Technologies (ICAT). 2013.
- [9] Ebben M. Logistic control in automated transportation networks. Enschede: University of Twente; 2001.
- [10] Tavana M, Fazlollahabbar H, Hassanzadeh R. A bi-objective stochastic programming model for optimising automated material handling systems with reliability considerations. *Int J Prod Res* 2014;52(19):5597–610.
- [11] Nakagawa T. Maintenance theory of reliability. Springer Series; 2005.

- [12] Cho DI, Parlar M. A survey of maintenance models for multi-unit systems. *Eur J Oper Res* 1991;51(1):1–23.
- [13] Lei Y, Liu J, Ni J, Lee J. Production line simulation using STPN for maintenance scheduling. *J Intell Manufact* 2010;21(2):213–21.
- [14] Fornlöf V, Galar D, Syberfeldt A, Almgren T. RUL estimation and maintenance optimization for aircraft engines: a system of system approach. *Int J Syst Assurance Eng Manage* 2016;7(4):450–61.
- [15] Petri CA. *Kommunikation Mit Automaten*. 1962. Phd Thesis.
- [16] Yang SK, Liu TS. A PETRI net approach to early failure detection and isolation for preventive maintenance. *Qual Reliab Eng Int* 1998;14(5):319–30.
- [17] Löfstrand M, Reed S, Karlberg M, Andrews J, Karlsson L, Dunnett S. Modelling and simulation of functional product system availability and support costs. *Int J Product Dev* 2012;16(3/4):304–25.
- [18] Leigh JM, Dunnett SJ. Use of Petri nets to model the maintenance of wind turbines. *Q Reliab Eng Int* 2016;32(1):167–80.
- [19] Jensen K, Jensen K. *Coloured Petri Nets, Vols. Jensen, K. Coloured petri Nets: basic Concepts, analysis methods and practical use*. Springer: Heidelberg, Germany; 2015. Heidelberg, Germany: Springer, 2015.
- [20] David R, Hassane A. Petri Nets for Modeling of Dynamic Systems A Survey. *Automatica* 1994;30(2):175–202.
- [21] Yan R, Jackson LM, Dunnett SJ. Automated guided vehicle mission reliability modelling using a combined fault tree and Petri net approach. *Int J Adv Manufact Technol* 2017.
- [22] Wu N, Zeng W. Deadlock avoidance in an automated guidance vehicle system using a coloured Petri net model. *Int J Prod Res* 2002;40(1):223–38.
- [23] Aized T. Modelling and performance maximization of an integrated automated guided vehicle system using coloured Petri net and response surface methods. *Comput Industr Eng* 2009;57(3):822–31.